



SkyView HDX

Autopilot Servo Installation & Maintenance Manual

Beechcraft Series 36

Includes Instructions for Continued Airworthiness (ICA)

STC SA02594SE

103736-000

Copyright © 2023 by Dynon Avionics, Inc.

Dynon Avionics grants third parties' permission to print this document.

Contact Information

Dynon Avionics, Inc.
19825 141st Place NE
Woodinville, WA 98072

Technical Support

Phone: +1 (425) 399-7742, 8:00 AM – 5:00 PM (Pacific Time) Monday – Friday
Email: support@dynoncertified.com

Sales

Phone: +1 (425) 650-1269, 8:00 AM – 5:00 PM (Pacific Time) Monday – Friday
Email: sales@dynoncertified.com

Find Us on the Web

dynoncertified.com – Dynon Certified homepage
dynoncertified.com/docs – Product documentation
dynoncertified.com/download – Software updates for products
dynoncertified.com/support – Support resources
dynoncertified.com/register – Register your Dynon Avionics product

Stay in Touch

dynoncertified.com/newsletter – Sign up to receive Dynon’s newsletter
forum.flydynon.com – Dynon-hosted forum for customers and pilots
preflight.dynon.com – Dynon’s blog
facebook.com/dynonavionics
instagram.com/dynonavionics
twitter.com/dynon

Videos and Training

youtube.com/DynonAvionics – Training, events, and other videos on YouTube

Copyright

©2023 Dynon Avionics, Inc. All rights reserved. No part of this manual may be reproduced, copied, transmitted, disseminated, or stored in any storage medium, for any purpose without the express written permission of Dynon Avionics. Dynon Avionics hereby grants permission to download a single copy of this manual and of any revision to this manual onto a hard drive or other electronic storage medium to be viewed for personal use, provided that such electronic or printed copy of this manual or revision must contain the complete text of this copyright notice and provided further that any unauthorized commercial distribution of this manual or any revision hereto is strictly prohibited.

Information in this document is subject to change without notice. Dynon Avionics reserves the right to change or improve its products and to make changes in the content without obligation to notify any person or organization of such changes. Visit the Dynon Avionics website (dynon.com) for current updates and supplemental information concerning the use and operation of this and other Dynon Avionics products.

Revision History

REV	DYNON SUBMITTAL DATE	DESCRIPTION OF CHANGES
A	5/14/2021 ECO 350348	Initial Submission
B	9/3/2021 ECO 374581	<ul style="list-style-type: none"> Revised Revision History table per FAA feedback received on 9/2/2021. Revised intro in Section 1 per FAA feedback received on 9/2/2021. Added <i>EFIS-D10A Installation & Maintenance Manual</i> document to Section 1.5. Revised Section 2 per FAA feedback received on 9/2/2021. Removed first note in Section 3.1, as it did not apply to this document. Added additional 1/8" bridle cable clamps and hardware to Table 1 to accommodate different positioning of roll servo bridle cable clamps. Added new tool to Section 6.1. Added two new notes to Sections 6.2, 6.3, 6.4, 11.8, 11.9, and 11.10 about removing aircraft power and deburring holes. Updated hole-drilling steps in Sections 6.2, 6.3, and 6.4 to be less confusing to installer. Added a step in Section 6.2 to determine if the aileron control cable requires 5/32" or 1/8" bridle cable clamps on inboard side of roll servo. Added a step in Sections 6.2, 6.3, 6.4, 11.8, 11.9, and 11.10 to make sure control cable is clean. Added Section 9: Autopilot Operation and referenced the <i>SkyView HDX Airplane Flight Manual Supplement</i> document per FAA feedback received on 9/1/2021. Subsequent sections renumbered. Revised Section 10.2 per updated troubleshooting procedures and clarity. Added Section 10.3 as a result of revising Section 10.2. Added Figure 15 to show installation of 1/8" bridle cable clamps on inboard side of roll servo. Subsequent figures renumbered.
C	10/21/2021 ECO 374581	<ul style="list-style-type: none"> Updated document numbering to GAMA2 numbering standard. Revised Revision Table to be clearer that some submitted revisions were not accepted by FAA. Removed FAA Approval section per FAA feedback received on 9/21/2021. Revised Section 2 per FAA feedback received on 9/21/2021. Renamed, revised, and moved Section 9: Autopilot Operation to Section 3: Basic Controls and Operation. Subsequent sections renumbered. Revised intro of Section: 11.5: Servo Capstan Removal and Attachment to clarify that this procedure is for the temporary removal and attachment of capstans. Revised Sections 11.8, 11.9, 11.10 to be consistent with Sections 7.2, 7.3, 7.4. Renamed Sections 11.8, 11.9, 11.10 from Removal and Installation to Removal and Replacement to be consistent with nomenclature in 8110.54a. <p>Accepted by Seattle ACO on 11/10/2021.</p>
D	01/06/2022 ECO 377153	<ul style="list-style-type: none"> Revised Contact Information section and links within doc with current URL addresses. Added a note in intro of Sections 7.3 and 7.4 to clarify that the pitch and yaw servo bracketry must be fully installed.
E	05/23/2022 ECO 379087	<ul style="list-style-type: none"> Updated Figures 29, 30, and 32 for clarity.

F	04/14/2023 ECO 385787	<ul style="list-style-type: none"> • Removed FAA Acceptance column from Revision History table per feedback from AACO. (No change bar for this change.) • Updated outdated verbiage throughout document. (No change bars for these changes.) • Updated Table 2, adding materials for S/N # E1-E571 pitch servo installation and new yaw servo bridle cable roller. • Revised Section 5: Control Cable Verification to add more specificity. • Revised Section 7.3: Pitch Servo Installation to add steps required to install pitch servo in S/N # E1-E571. • Revised Section 7.3: Yaw Servo Installation to add steps required to install new yaw servo bridle cable roller. • Added Section 8.1: Custom Wire Harness Preparation, which is boilerplate content included in recent autopilot installation manuals. • Revised Section 11.10: Yaw Servo Removal and Replacement to add steps required to install new yaw servo bridle cable roller. • Updated Section 12.2: Pitch Servo Figures to add steps required to install pitch servo in S/N # E1-E571. • Updated Section 12.3: Yaw Servo Figures to add steps required to install new yaw servo bridle cable roller.
G	09/05/2023 ECO 387411	<ul style="list-style-type: none"> • Revised Table 2: Pitch and Yaw Servo Installation Materials for inclusion of new pitch/yaw bracket assembly gussets and braces and associated hardware. • Revised Section 7.4: Yaw Servo Installation for inclusion of new pitch/yaw bracket assembly gussets and braces. • Updated figure item numbers in Section 12.2: Pitch Servo Figures and Section 12.3: Yaw Servo Figures. (No change bars for this change.) • Added two new figures and revised one figure in Section 12.3: Yaw Servo Figures for inclusion of new pitch/yaw bracket assembly gussets and braces.

Bars in margins denote technical document changes since last published revision.

Table of Contents

1	Introduction	1-1
1.1	Document Control.....	1-1
1.2	Using this Manual	1-1
1.3	Intended Audience.....	1-1
1.4	Manual Iconography	1-2
1.5	Reference Documents.....	1-2
1.6	Mechanical Drawings	1-2
1.7	Product Delivery	1-2
1.8	Product Registration	1-3
1.9	Installation Record.....	1-3
2	Airworthiness Limitations	2-1
3	Basic Control and Operation	3-1
4	Installation Compliance	4-1
4.1	Pre-installation Information.....	4-1
5	Control Cable Verification	5-1
6	Materials	6-1
7	Initial Servo and Bracketry Installation.....	7-1
7.1	Additional Tools	7-1
7.2	Roll Servo Installation.....	7-1
7.3	Pitch Servo Installation	7-6
7.4	Yaw Servo Installation	7-11
8	Servo Electrical Connection.....	8-1
8.1	Custom Wire Harness Preparation	8-2
9	Electric Trim Control.....	9-1
10	Servo Troubleshooting	10-1
10.1	Servos Offline Messages.....	10-1
10.2	Servo Slip Messages	10-2
10.3	Abnormal Operation	10-2
11	Servo Maintenance.....	11-1
11.1	Service	11-1

11.2	Calibration Procedure	11-1
11.3	Test Procedure	11-2
11.4	Servo Operation Check	11-2
11.5	Servo Capstan Removal and Attachment.....	11-4
11.6	Cable Guard Adjustment	11-5
11.7	Shear Screw Replacement.....	11-5
11.8	Roll Servo Removal and Replacement.....	11-6
11.9	Pitch Servo Removal and Replacement	11-9
11.10	Yaw Servo Removal and Replacement	11-12
12	Figures	12-1
12.1	Roll Servo Figures	12-1
12.2	Pitch Servo Figures	12-16
12.3	Yaw Servo Figures	12-34
12.4	Servo Capstan Removal/Installation Figure	12-49

1 Introduction

This document provides installation and configuration information for SkyView HDX autopilot servos and bracketry in Beechcraft Bonanza Model 36 series of airplanes. It also provides Instructions for Continued Airworthiness (ICA) for use by authorized personnel to service and maintain the servos according to Federal Aviation Regulation (FAR) 14 CFR § 23.1529 and 14 CFR 23 Appendix G.

This document does not provide ICA for the SkyView HDX system or the EFIS-D10A Standby Flight Display. That information is provided in the *SkyView HDX General Maintenance Manual* document and the *EFIS-D10A Installation & Maintenance Manual* document at dynoncertified.com/docs.

1.1 Document Control

This document is released, archived, and controlled according to the Dynon Avionics document control system. To revise this document, a letter is submitted to the FAA with the revision. The FAA then accepts and approves any revision to Section 2: [Airworthiness Limitations](#). After FAA acceptance/approval, Dynon posts the revised document for customer use at dynoncertified.com/docs, and STC owners and installers are notified of the new revision via an official Dynon Marketing email release.

1.2 Using this Manual

To save paper, Dynon Avionics does not provide a printed version of this manual. However, Dynon grants permission to third parties to print this manual, as necessary. The most recent PDF version is available for download at dynoncertified.com/docs. This manual is updated periodically. It is important to use the most recent version when servicing SkyView components.

Dynon suggests keeping a PDF version of the manual on a smartphone, tablet, or laptop computer while servicing SkyView components. Using the manual electronically allows quick navigation of the document, figures to be viewed in color, and keyword searches.

1.3 Intended Audience

This document is intended for FAA-certified Airframe and Powerplant Technicians. It assumes technicians have the typical aircraft knowledge and training required to perform the procedures in this manual.

1.4 Manual Iconography

This manual uses the following iconography:



Alerts reader to critical guidance that if not followed could result in an unsafe condition.



Alerts reader to FAA regulatory information.



Alerts reader to important installation and/or maintenance information.



Alerts reader to helpful tips or suggestions.

1.5 Reference Documents

The following documents are referenced in or supplement this manual:

- 103261-000 SkyView HDX System Installation Manual, *current revision*
- 103914-000 EFIS-D10A Installation & Maintenance Manual, *current revision*
- 103221-000 SkyView HDX General Maintenance Manual, *current revision*
- 103488-000 SkyView HDX Wiring Diagram - Single Engine, *current revision*
- 103272-000 SkyView HDX Airplane Flight Manual Supplement, *current revision*
- 103777-000 SkyView HDX System Equipment Installation Record, *current revision*
- 103000-000 Dynon Servo Shear Screw Replacement Kit Instructions, *current revision*
- FAR 23.1311-1C - Installation of Electronic Display in Part 23 Airplanes
- AC 43.13-1B - Acceptable Methods, Techniques, and Practices - Aircraft Inspection
- AC 43.13-2B - Acceptable Methods, Techniques, and Practices - Aircraft Alterations

1.6 Mechanical Drawings

All mechanical drawings included in this manual are for *reference purposes only*. They should not be scaled or copied and used as templates or patterns.

1.7 Product Delivery

Upon delivery, visually inspect all SkyView Autopilot components, brackets, fasteners, cable harnesses, and accessories for damage that may have occurred during shipping. If damage has occurred, contact Dynon Technical Support.

1.8 Product Registration

Register SkyView components at dynoncertified.com/register. Product registration verifies ownership, expedites warranty claims, and allows Dynon Avionics to send notification when product Service Bulletins and Technical Advisories are published. This site also allows owners and installers to register to receive news and product announcements from Dynon. Dynon will not share contact information with third-parties or send announcements without explicit consent.

1.9 Installation Record

The technician performing the installation should record where the equipment has been installed in the airplane. This documentation should be entered into airplane's permanent record. Dynon provides a document template to record this information. Download the *SkyView HDX Equipment Installation Record* document at dynoncertified.com/docs.

This page intentionally left blank.

2 Airworthiness Limitations

For any Airworthiness Limitations associated with the installation of SkyView Autopilot servos, see the *SkyView HDX General Maintenance Manual* document at dynoncertified.com/docs. It is the principal ICA document for the SkyView HDX system.

This page intentionally left blank.

3 Basic Control and Operation

Pilots interact with all Autopilot functions through a SkyView HDX display unit. No special operating procedures are required for using the Autopilot. Control descriptions and detailed operating procedures are found in the *103272-000 SkyView HDX Airplane Flight Manual Supplement* document at dynoncertified.com/docs.

Operating limitations for the Autopilot are listed in the *103272-000 SkyView HDX Airplane Flight Manual Supplement* document at dynoncertified.com/docs.

This page intentionally left blank.

4 Installation Compliance

If the airplane receiving the installation has been modified, it may be difficult to use the information in this manual to completely substantiate the installation in compliance with STC SA02594SE. Therefore, it is the installer's responsibility to make the final determination of applicability for each individual airplane.

Prior to completing the installation, and before returning the airplane to service, the installer must complete and submit a completed Form FAA 337 - Major Repair & Alteration (Airframe, Powerplant, Propeller, or Appliance) to the appropriate FAA Aircraft Registration Branch. The form must include the following:

- Description of the autopilot servo installation.
- Description of how the autopilot servos interface with existing equipment and systems.
- Appropriately approved or acceptable data that demonstrates compliance.

Refer to AC 43.9-1G - Instructions for Completion of FAA Form 337 for additional information.

4.1 Pre-installation Information

Read and understand the following before proceeding with installation activities.

Always install avionics equipment in accordance with the instructions in this manual and the guidance and approved engineering methods outlined the following FAA documents:



- AC 23.1311-1C - Installation of Electronic Display in Part 23 Airplanes
- AC 43.13-1B - Acceptable Methods, Techniques, and Practices - Aircraft Inspection
- AC 43.13-2B - Acceptable Methods, Techniques, and Practices - Aircraft Alterations



The technician who will authorize the airplane's return to service should agree with the installation plan (i.e., methods, component locations, wiring harness routing, etc.) before installation activities begin. This will help avoid potential rework should any part of the installation be found non-compliant.

This page intentionally left blank.

5 Control Cable Verification

The SkyView Autopilot system for the Beechcraft Bonanza Model 36 series of airplanes is designed to attach to the airplane's original control cables. It is important for installers to verify the condition, rigging, tension, and diameter of the control cables before starting installation activities. The diameter of control cables should be measured in the vicinities where the autopilot servos will be installed.



DO NOT connect an autopilot system to improperly rigged and tensioned control cables. This includes control cables that are frayed or do not meet manufacturers' specifications.

To inspect the aileron control cable, installers need to access the area under left rear seat near FS118.5 (see [Figure 1](#) for exact location) in accordance with the manufacturer's service manual. To inspect the elevator and rudder control cables, installers need to access the area behind the baggage area near FS207 (see [Figure 17](#) for exact location) in accordance with the manufacturer's service manual.

Dynon's bridle cable clamps are designed to meet the requirements below for wire rope as specified by MIL-DTL-83420.

CONTROL CABLE	NOMINAL DIAMETER	MINIMUM DIAMETER	MAXIMUM DIAMETER
Aileron ¹	5/32" or, 5/32" and 1/8"	0.156" or, 0.156" and 0.125"	0.172" or, 0.172" and 0.139"
Elevator	1/8"	0.125"	0.139"
Rudder	1/8"	0.125"	0.139"

1) Roll servo installation kit includes materials for both 5/32" and 1/8" control cables.



If the airplane's original control cables are outside this specification, contact Dynon Technical Support for a resolution.

Out-of-specification control cables can cause cable clamps to slip under load.

This page intentionally left blank.

6 Materials

The materials identified in [Table 1](#) are provided to install the roll servo. ITEM numbers are also used to call-out parts in the figures in [Section 12.1: Roll Servo Figures](#).

Table 1: Roll Servo Installation Materials

ITEM	DYNON P/N	DESCRIPTION	QTY
1	503406-000	SERVO ASSEMBLY: SV42C-SERVO, CAPSTAN 1.0" R	1
1-1		SV42C SERVO	1
1-2		CAPSTAN 1.0" R	1
1-3		AN310-5 CASTLE NUT	1
1-4		WAVE WASHER 5/16"	1
1-5		NYLON WASHER 5/16"	1
1-6		PHILLIPS PAN HEAD SCREW #6-32 X 1/4", NYLOK	4
1-7		MS35333-37 INTERNAL TOOTH WASHER	4
1-8		CABLE GUARD	1
2A	503672-000	CAPSTAN ACCESSORY KIT, 5/32" CONTROL CABLE	1
2-1		AN365-10 LOCK NUT	6
2-2		AN960 FLAT WASHER	6
2-3		AN3-6A HEX BOLT	6
2-4		BRIDLE CABLE CLAMP 5/32"	4
2-5		BRIDLE CABLE 1/16"	1
2-6		ST2-2 STOP SWAGE, 1/16" CABLE	2
2B	503560-000	BRIDLE CABLE CLAMP KIT, 1/8" CONTROL CABLE	1
2-7		AN365-10 LOCK NUT	3
2-8		AN960 FLAT WASHER	3
2-9		AN3-6A HEX BOLT	3
2-10		BRIDLE CABLE CLAMP 1/8"	2
3	504179-000	ROLL SERVO PLATE BRACKET	1

ITEM	DYNON P/N	DESCRIPTION	QTY
4	504178-000	ROLL SERVO FORWARD SUPPORT BRACKET	1
5	504177-000	ROLL SERVO REAR SPAR BRACKET	1
6	104112-000	ROLL SERVO INSTALLATION HARDWARE KIT	1
6-1		MS24665-210 COTTER PIN	1
6-2		AN525-832R8 PHILLIPS WASHER HEAD SCREW	4
6-3		AN365-832A LOCK NUT	4
6-4		AN960-08 FLAT WASHER	4
6-5		AN3H-4A HEX BOLT, DRILLED HEAD	4
6-6		AN3-4A HEX BOLT	4
6-7		AN960-10 FLAT WASHER	8
6-8		CR3213-5-2 CHERRYMAX RIVET	4

Items without Dynon part numbers are parts that are only sold as a kit.

The materials identified in [Table 2](#) are provided to install the pitch and yaw. ITEM numbers are also used to call-out parts in the figures in [Section 12.2: Pitch Servo Figures](#).

Table 2: Pitch and Yaw Servo Installation Materials

ITEM	DYNON P/N	DESCRIPTION	QTY
7	503679-000	SERVO ASSEMBLY: SV32C SERVO, CAPSTAN 1.5" R (Used for Pitch)	1
7-1		SV32C SERVO	1
7-2		CAPSTAN 1.5" R	1
7-3		AN310-5 CASTLE NUT	1
7-4		WAVE WASHER 5/16"	1
7-5		NYLON WASHER 5/16"	1
7-6		PHILLIPS PAN HEAD SCREW	4
7-7		MS35333-37 INTERNAL TOOTH WASHER	4
7-8		CABLE GUARD	1
8	503933-000	SERVO ASSEMBLY: SV42C SERVO, CAPSTAN 0.68" R (Used for Yaw)	1
8-1		SV42C SERVO	1
8-2		CAPSTAN 0.68" R	1
8-3		AN310-5 CASTLE NUT	1
8-4		WAVE WASHER 5/16"	1
8-5		NYLON WASHER 5/16"	1
8-6		PHILLIPS PAN HEAD SCREW #6-32 X 1/4", NYLOK	4
8-7		MS35333-37 INTERNAL TOOTH WASHER	4
8-8		CABLE GUARD	1
9A	503674-000	CAPSTAN ACCESSORY KIT	2
9-1		AN365-10 LOCK NUT	12
9-2		AN960 FLAT WASHER	12
9-3		AN3-6A HEX BOLT	12
9-4		BRIDLE CABLE CLAMP 1/8", 1/16"	8

ITEM	DYNON P/N	DESCRIPTION	QTY
9-5		BRIDLE CABLE 1/16"	2
9-6		ST2-2 STOP SWAGE, 1/16" CABLE	4
9B	504583-000	BRIDLE CABLE CLAMP KIT, 5/32" CONTROL CABLE ¹	1
9-7		AN365-10 LOCK NUT ¹	6
9-8		AN960 FLAT WASHER ¹	6
9-9		AN3-6A HEX BOLT ¹	6
9-10		BRIDLE CABLE CLAMP 5/32", 1/16" ¹	4
10	503872-000	PITCH SERVO SHELF BRACKET	1
11	503876-001	STRINGER SPACER	2
12	503989-000	SHELF BRACKET SPACER 1/4"	2
13	503900-000	PITCH CONTROL CABLE RUB STRIP	1
14	503882-000	ACCESS COVER PLATE	1
15	503873-000, 503873-001	YAW SERVO BRIDGE BRACKET ²	1
16	503875-000, 503875-001	YAW SERVO BOXING PLATE ²	1
17	503895-002	PITCH/YAW SERVO BRACKET ASSY BRACE	2
18	504751-001	PITCH/YAW SERVO BRACKET ASSY GUSSET, LH	1
19	504767-001	PITCH/YAW SERVO BRACKET ASSY GUSSET, RH	1
20	504667-000	YAW SERVO ROLLER BRACKET	1
21	504669-000	YAW SERVO ROLLER	1
22	104787-000	STRINGER TEMPLATE, UPPER	1
23	104788-000	STRINGER TEMPLATE, LOWER	1
22	104114-000	PITCH/YAW SERVO INSTALLATION HARDWARE KIT	1
22-1		MS24665-210 COTTER PIN	2
22-2		MS35206-245 PHILLIPS PAN HEAD SCREW	6
22-3		AN960-8 FLAT WASHER	14

ITEM	DYNON P/N	DESCRIPTION	QTY
22-4		AN525-832R12 PHILLIPS WASHER HEAD SCREW	4
22-5		AN365-832A HEX LOCK NUT	8
22-6		AN3-5A HEX BOLT	2
22-7		AN960-10 FLAT WASHER	38
22-8		AN365-1032A HEX LOCK NUT	12
22-9		AN3H-4A HEX BOLT, DRILLED HEAD	8
22-10		AN3-4A HEX BOLT	27
22-11		AN3-17 HEX BOLT #10-32 X 2" DRILLED SHANK	1
22-12		AN310-3 CASTLE NUT #10-32	1
22-13		AN525-832-R7 PHILLIPS WASHER HEAD SCREW	4
22-14		MS24665-132 COTTER PIN	1
23	504610-000	PITCH SERVO MOUNT ADAPTER KIT (Used for S/N E1-E571)	1
23-1	104608-000	PITCH SERVO AFT ADAPTER BRACKET	1
23-2	104607-000	PITCH SERVO FWD ADAPTER BRACKET	1
23-3	104609-000	PITCH SERVO ADAPTER TEMPLATE	1
23-4		AN3H-3A HEX BOLT, DRILLED HEAD	4
23-5		AN3-4A HEX BOLT	4
23-6		AN960-10 FLAT WASHER	8
23-7		AN365-1032 LOCK NUT	4

Items without Dynon part numbers are parts that are only sold as a kit.

- 1) Parts packaged in a kit, but unused in Beechcraft Bonanza Model 36 installations.
- 2) Parts ending in -000 and -001 are functionally equivalent.

This page intentionally left blank.

7 Initial Servo and Bracketry Installation

This section provides instructions for installing the roll, pitch, and yaw servos and bracketry, and then attaching bridle cable assemblies to the aileron, elevator, and rudder control cables. The instructions apply to all Bonanza Model 36 airplanes. These instructions assume that the areas affected by these installations are unmodified from the factory-delivered configuration.



Yaw servo installation is not supported in Bonanza 36 models, serial numbers E-1 through E-571.



Printing the figures at the end of this document and keeping them on-hand during installation activities is recommended.

7.1 Additional Tools

The following non-typical tools are needed to complete the installation:

- Nutplate Drill Jig for K1000-3/MS21047-L3 nutplates,
- Swage compression tool appropriate for ST2-2 stop swages,
- Cutters for 1/16" diameter wire rope.

7.2 Roll Servo Installation

The roll servo and bracketry are installed in the fuselage on the forward, left-hand side of the Rear Spar Carry Through near FS118.5 (see [Figure 1](#) for exact location). To install the roll servo, installers need to access this area in accordance with the manufacturer's service manual. See [Figure 11](#) for an example of a complete installation.



Remove any previously installed autopilot equipment that may interfere with the new servo installation.



Make sure all flight control cables are rigged and tensioned in accordance with manufacturer's instructions.



Always disconnect aircraft battery before starting installation activities.



Always deburr drilled holes.



Unless otherwise specified, torque all fasteners per specifications in AC 43.13-1B, Table 7-1. Include specified friction drag value when torquing screws.

To install the roll servo:

1. Remove capstan and cable guard from roll servo (see Section 11.5 for instructions).



DO NOT loosen or remove the shear screw from the servo disc!

2. Temporarily attach roll servo to plate bracket, as shown in Figure 3. Finger-tighten castle nut, and tighten, but do not torque hardware. Cotter pin and washers not needed yet.



Position servo capstan so orientation mark on capstan faces *away from* servo and is fully seated on servo disc. The capstan has a hole that fits over shear screw head.

3. Temporarily attach forward support bracket and rear spar bracket to plate bracket, as shown in Figure 4. Tighten, but do not torque hardware.
4. Place plate bracket into airplane, as shown in Figure 5 and Figure 6. Make sure aileron control cable is on top of assembly and to rear of servo capstan.



Positioning of servo capstan in relation to aileron control cable in height and distance is critical for an airworthy installation.

5. Position rear spar bracket on forward face of Rear Spar Carry Through so flanges on bracket span lightening hole (see Figure 5), and then clamp in place.
6. Loosen bolts securing forward support bracket and rear spar bracket to plate bracket (with roll servo).
7. Using slots in plate bracket, adjust and position assembly so aileron control cable is 1/4" aft of cable guard and tracks (inboard and outboard) down center of capstan (see Figure 6), and then secure in place. Tighten, but do not torque hardware.
8. On outboard side of lightening hole, use pilot holes on rear spar bracket as guides to match drill up to #30 holes through front side of spar web only (see Figure 7), and then temporarily fasten in place.
9. Use pilot holes on forward support bracket as guides to match drill up to #18 holes through bracket and floorboard stringer, as shown in Figure 7.
10. Remove forward support bracket and plate bracket.
11. Use pilot holes on rear spar bracket as guides to match drill up to #20 holes through bracket and front side of spar web only (see Figure 8).
12. Permanently rivet rear spar bracket to spar web, as shown in Figure 9.
13. Permanently fasten support bracket to floorboard stringer, as shown in Figure 10.
14. Remove capstan from roll servo.
15. Permanently fasten roll server to plate bracket, and then safety wire roll servo bolts (see Figure 11 for example).

16. Permanently fasten plate bracket assembly to forward support bracket and rear spar bracket, as shown in [Figure 12](#).

To attach the roll servo to the aileron control cable:

1. Secure ailerons in center of travel.
2. Insert bridle cable's engagement swage into capstan's engagement hole.
3. Start from swage engagement hole and wrap bridle cable 1/2 time in each direction around capstan, as shown in [Figure 13](#).



Securing (e.g., taping) the bridle cable to capstan grooves prevents cable from unraveling when handling.

4. Temporarily attach capstan to roll servo (see [Figure 13](#)). Finger-tighten castle nut. Cotter pin not needed yet.



Position servo capstan so orientation mark on capstan faces *away from* servo and is fully seated on servo disc. The capstan has a hole that fits over shear screw head.

5. Determine where inboard bridle cable clamps should attach to aileron control cable:
 - A. If bridle cable clamps fit on outboard side of the turnbuckle (see [Figure 14](#)), use the 5/32" clamps.
 - B. If bridle cable clamps fit on inboard side of the turnbuckle (see [Figure 15](#)), use the 1/8" clamps.
6. Make sure aileron control cable where bridle cable clamps will attach is clean and free of dirt and grease.



Roll servo installation kit contains bridle cable clamps for 5/32" and 1/8" diameter control cables, ensure correct clamps are used per determination in Step 5.

7. Use bridle cable clamps to loosely connect inboard and outboard bridle cable ends to control cable, as shown in [Figure 14](#) or [Figure 15](#).
8. Position bridle cable clamps so that:
 - Capstan is positioned as shown in [Figure 14](#) or [Figure 15](#).
 - Clamps are located as shown in [Figure 14](#) or [Figure 15](#).
 - Clamps are positioned to avoid contacting any structure.
9. Mark locations for swage stops on bridle cable at outside edges of bridle cable clamps.
10. Remove bridle cable clamps from bridle cable, and then remove capstan from roll servo.
11. Slide a swage stop onto one end of bridle cable so it is aligned with mark on bridle cable.
12. Permanently attach swage stop to bridle cable, and then trim bridle cable end flush with outside edge of swage stop.

13. Repeat Steps 11 and 12 on the other end of bridle cable.
14. Temporarily attach capstan to roll servo, as shown in [Figure 13](#). Finger-tighten castle nut. Cotter pin not needed yet.



Position servo capstan so orientation mark on capstan faces *away from* servo and is fully seated on servo disc. The capstan has a hole that fits over shear screw head.

15. Rotate capstan to locate swage engagement hole on opposite side of capstan from aileron control cable. Make sure bridle cable ends extend from capstan, as shown in [Figure 14](#) or [Figure 15](#).
16. Use bridle cable clamps to loosely connect bridle cable ends to aileron control cable, as shown in [Figure 14](#) or [Figure 15](#). Make sure clamps contact swage stops at each end of bridle cable.
17. Make sure bridle cable does not contact cable guard.



The bridle cable will prematurely wear if it contacts the cable guard throughout its travel.

18. If cable guard interferes with bridle cable, adjust cable guard position (see [Section 11.6: Cable Guard Adjustment](#)), and then repeat Step 17.
19. Tension and temporarily secure bridle cable to 15–20 lbs. Make sure swage engagement hole is on opposite side of capstan from aileron control cable.



The tension on the bridle cable should never exceed the manufacturer's specified tension for the control cable.

20. When satisfied with tension and capstan position, tighten all bridle cable clamp nuts to 35-40 in-lb.
21. Use a feeler gauge to measure gaps between bridle cable clamp halves (top and bottom). Make sure gaps meet the following criteria:
 - Gap measurements on both sides of clamp are not less than 0.003" and not more than 0.050".



If clamp gap measurements do not meet criteria above, measure diameter of control cable, and then contact Dynon Technical Support for a resolution.

Out-of-specification cable clamps can slip under load.

22. Permanently attach capstan to roll servo (see [Section 11.5](#) for instructions).

To check the roll servo installation:

1. Release ailerons.
2. Move aileron control through full range of motion per manufacturer's maintenance instructions, and verify the following:
 - Control is smooth throughout (i.e., no grinding, rubbing, or roughness).
 - Bridle cable clamps do not contact any structures during entire travel.
 - Capstan never rotates more than 150 degrees in either direction from neutral.
3. Cycle the control several times, return it to neutral, and verify the following:
 - Position of bridle cable clamps closely matches [Figure 14](#) or [Figure 15](#).
 - Capstan orientation mark is positioned as shown in [Figure 14](#) or [Figure 15](#).
 - Bridle cable tension has not changed.

7.3 Pitch Servo Installation

The pitch servo and bracketry are installed in the fuselage, behind the frame at FS207 (see [Figure 17](#) for exact location). To install the pitch servo, installers need to access this area in accordance with the manufacturer's service manual. See [Figure 49](#) for an example of a complete installation.



The pitch and yaw servo bracketry must be installed as a complete fixture even if the installation does not include a yaw servo.



Aircraft S/N # E-1–E-571, require additional steps and materials to install the pitch servo bracketry. These steps are identified in the installation procedures.



Remove any previously installed autopilot equipment that may interfere with the new servo installation.



Make sure all flight control cables are rigged and tensioned in accordance with manufacturer's instructions.



Always disconnect aircraft battery before starting installation activities.



Always deburr drilled holes.



Unless otherwise specified, torque all fasteners per specifications in AC 43.13-1B, Table 7-1. Include specified friction drag value when torquing screws.

To install the pitch servo:

1. Remove capstan and cable guard from pitch servo (see [Section 11.5](#) for instructions.)



DO NOT loosen or remove the shear screw from the servo disc!

2. Attach cable rub strip to pitch servo shelf bracket (see [Figure 20](#)).
3. Optionally, attach access cover plate to shelf bracket (see [Figure 20](#)).



The opening in the shelf bracket provides access to the autopilot servos for visual inspection and ease of installation.

4. *For aircraft S/N # E1–E571*, use provided template to mark and then cut an opening in shelf bracket, as shown in [Figure 21](#).

5. Position stringer spacers on left and right fuselage stringers behind FS207 frame, as shown in [Figure 22](#). Make sure spacers are positioned as far inboard as possible.



Positioning stringer spacers firmly against return "J" flange on stringers is critical to preventing hardware from contacting existing rivet heads.

6. Position shelf bracket behind FS207 frame, as shown [Figure 22](#). Make sure outboard attachment flanges rest on stringer spacers.



Positioning shelf bracket so it is square to the fuselage is critical to aligning other brackets later in the installation.

7. Slide shelf bracket and stringer spacers forward until bracket's forward attachment flanges contact beads formed into FS207 frame. Make sure bracket remains is aligned with frame, as shown in [Figure 23](#).
8. Clamp shelf bracket to fuselage stringers and FS207 frame.
9. Use [Figure 23](#) to identify tooling holes near bottom of each side of FS207 frame.
10. Use tooling holes as guides to match drill up to #10 holes through FS207 frame and shelf bracket's forward attachment flanges, and then temporarily fasten in place, as shown in [Figure 24](#).
11. Use holes in shelf bracket's outboard attachment flanges as guides to match drill up to #18 holes through flanges and fuselage stringers, as shown in [Figure 22](#).
12. Remove shelf bracket from aircraft.
13. For aircraft S/N # E1–E571, do the following to secure pitch servo to shelf bracket:
 - A. Attach adapter brackets to pitch servo (see [Figure 25](#)).
 - B. Safety wire pitch servo bolts (see [Figure 26](#) for example).
 - C. Clamp adapter brackets (with pitch servo) to shelf bracket (see [Figure 27](#)).
 - D. Use holes in adapter brackets as guides to match drill up to #10 holes through adapter brackets and shelf bracket, as shown in [Figure 27](#).
 - E. Secure adapter brackets (with pitch servo) to shelf bracket, as shown in [Figure 27](#).
14. For aircraft S/N # E572 and on, do the following to secure pitch servo to shelf bracket:
 - A. Attach pitch servo to shelf bracket (see [Figure 28](#)).
 - B. Attach cable guard to pitch servo (see [Figure 29](#)).
 - C. Safety wire pitch servo bolts (see [Figure 30](#) for example).
15. Permanently secure shelf bracket to aircraft, as shown in [Figure 22](#) and [Figure 24](#).

To attach the pitch servo to the elevator up control cable:

1. Secure elevator in center of travel.
2. Insert bridle cable's engagement swage into capstan's engagement hole.
3. Start from swage engagement hole and wrap bridle cable 1 time in each direction around capstan.



Securing (e.g., taping) the bridle cable to capstan groove prevents cable from unraveling when handling.

4. For aircraft S/N # E1–E571, temporarily attach capstan and cable guard to pitch servo, as shown in [Figure 31](#). Cotter pin not needed yet.
5. For aircraft S/N # E572 and on, temporarily attach capstan pitch servo, as shown in [Figure 32](#). Cotter pin not needed yet.



Position servo capstan so orientation mark on capstan faces *toward* servo and is fully seated on servo disc. The capstan has a hole that fits over shear screw head.

6. Make sure elevator control cable where bridle cable clamps will attach is clean and free of dirt and grease.
7. Use 1/8" bridle cable clamps to loosely connect forward and aft bridle cable ends to elevator control cable, as shown in [Figure 33](#) or [Figure 34](#).
8. Position bridle cable clamps so that:
 - Swage engagement hole is on same side of capstan as control cable.
 - Clamps are located as shown in [Figure 33](#) or [Figure 34](#).
 - Clamps are positioned to avoid contacting any structures.
9. Mark locations for swage stops on bridle cable at outside edges of cable clamps.
10. Remove bridle cable clamps from bridle cable, and then remove capstan and cable guard from pitch servo (see Section [11.5](#) for instructions).
11. Slide a swage stop onto one end of bridle cable so it is aligned with mark on bridle cable.
12. Permanently attach swage stop to bridle cable, and then trim bridle cable end flush with outside edge of swage stop.
13. Repeat Steps 10 and 11 for opposite end of bridle cable.
14. Temporarily attach capstan to pitch servo, as shown in [Figure 31](#) or [Figure 32](#). Cotter pin not needed yet.



Position servo capstan so orientation mark on capstan faces *toward* servo and is fully seated on servo disc. The capstan has a hole that fits over shear screw head.

15. Rotate capstan to locate swage engagement hole on opposite side of capstan from elevator control cable. Make sure bridle cable ends extend from capstan, as shown in [Figure 33](#) or [Figure 34](#).
16. Use bridle cable clamps to loosely connect bridle cable ends to elevator control cable, as shown in [Figure 33](#) or [Figure 34](#). Make sure clamps contact swage stops at each end of bridle cable.
17. Make sure bridle cable does not contact cable guard.



The bridle cable will prematurely wear if it contacts the cable guard throughout its travel.

18. If cable guard interferes with bridle cable, adjust cable guard position (see Section [11.6: Cable Guard Adjustment](#)), and then repeat Step 16.
19. Tension and temporarily secure bridle cable to 15–20 lbs. Make sure swage engagement hole is on opposite side of capstan from elevator up cable.



The tension on the bridle cable should never exceed the manufacturer's specified tension for the control cable.

20. When satisfied with tension and capstan position, tighten all bridle cable clamp nuts to 35-40 in-lb.
21. Use a feeler gauge to measure gaps between bridle cable clamp halves (top and bottom). Make sure gaps meet the following criteria:
 - Gap measurements on both sides of clamp are not less than 0.003" and not more than 0.050".



If clamp gap measurements do not meet criteria above, measure diameter of control cable, and then contact Dynon Technical Support for a resolution.

Out-of-specification cable clamps can slip under load.

22. Permanently attach capstan and cable guard to pitch servo (see Section [11.5](#) for instructions).

To check the pitch servo installation:

1. Release elevator.
2. Move elevator control through full range of motion per manufacturer's maintenance instructions, and verify the following:
 - Control is smooth throughout (i.e., no grinding, rubbing, or roughness).
 - Bridle cable clamps do not contact any structures during entire travel.
 - Capstan never rotates more than 150 degrees in either direction from neutral.
3. Cycle the control several times, return it to neutral, and verify the following:
 - Position of bridle cable clamps closely matches [Figure 33](#) or [Figure 34](#).
 - Swage engagement hole is on same side of capstan as control cable.
 - Bridle cable tension has not changed.

7.4 Yaw Servo Installation

The yaw servo and its bracketry are installed in the fuselage, behind the frame at FS207 (see [Figure 17](#) for exact location). It is installed (i.e., stacked) on top of the pitch servo bracketry. To install the yaw servo, installers need to remove the FS170 access panel located behind the baggage area in accordance with the manufacturer's service manual. See [Figure 49](#) for an example of a complete installation.



Yaw servo installation is not supported in Bonanza 36 models, serial numbers E-1 through E-571.



The pitch and yaw servo bracketry must be installed as a complete fixture even if the installation does not include a yaw servo.



Remove any previously installed autopilot equipment that may interfere with the new servo installation.



Make sure all flight control cables are rigged and tensioned in accordance with manufacturer's instructions.



Always disconnect aircraft battery before starting installation activities.



Always deburr drilled holes.



Unless otherwise specified, torque all fasteners per specifications in AC 43.13-1B, Table 7-1. Include specified friction drag value when torquing screws.

To install the yaw servo:

1. Remove capstan and cable guard from yaw servo (see [Section 11.5](#) for instructions.)



DO NOT loosen or remove the shear screw from the servo disc!

2. Secure yaw servo to bridge bracket (see [Figure 35](#)).
3. Reattach cable guard to yaw servo (see [Figure 36](#)).
4. Safety wire yaw servo bolts (see [Figure 37](#) for an example).
5. Attach boxing plate to bridge bracket (see [Figure 38](#).) Do not fully tighten hardware yet.



Depending upon time of purchase, the boxing plate and bridge bracket may have stickers that cover an unused fastener hole.

6. Attach roller bracket to bracket assembly (see [Figure 39](#)). Do not fully tighten hardware yet.

7. Install roller, as shown in [Figure 40](#). Finger-tighten castle nut onto roller bolt, and then use a wrench to tighten until a slot in castle nut lines up with hole for cotter pin.



DO NOT overtighten the castle nut!

Overtightening the castle nut may prevent the roller from moving freely.

8. Verify that roller moves freely and use a feeler gauge to ensure a gap between roller and bracket of at least 0.005".
9. Insert bridle cable's swage into capstan's engagement hole (see [Figure 41](#)).
10. Start from swage engagement hole and wrap bridle cable 1-1/4 times in each direction around capstan, as shown in [Figure 41](#).



Securing (e.g., taping) the bridle cable to capstan grooves prevents cable from unraveling when handling.

11. Attach capstan to yaw servo, as shown in [Figure 41](#).



Position servo capstan so orientation mark on capstan faces *toward* servo and is fully seated on servo disc. The capstan has a hole that fits over shear screw head.

12. Install yaw servo and bracket assembly, as shown in [Figure 42](#).
13. Locate existing gussets on FS207 frame [Figure 43](#) and then remove inboard rivets (see [Figure 43](#)) that secure gussets to frame.
14. Using provided templates, mark centerlines on gussets and stringers, as shown in [Figure 44](#).
15. Temporarily fasten gussets to stringers, as shown in [Figure 45](#).



The upper stringer template is disposable and may be drilled through when match drilling the stringers.

16. Attach gussets to FS207 frame (see [Figure 46](#)), and then remove temporary fasteners and attach gussets to stringers. Do not fully tighten hardware yet.
17. Attach braces to gussets and boxing plate, as shown in [Figure 47](#). If needed, trim excess material from bottom end of braces (see [Figure 47](#)).



If needed, the angle on the gusset flange may be altered +/- 3°.

18. Fully tighten bracket assembly hardware.

To attach the yaw servo to the rudder control cables:

1. Secure rudder in center of travel.
2. Make sure rudder control cables where bridle cable clamps will attach are clean and free of dirt and grease.
3. Use 1/8" bridle cable clamps to loosely connect bridle cable ends to rudder control cables, as shown in [Figure 48](#).
4. Position bridle cable clamps so that:
 - Bridle cable travels over roller, as shown in [Figure 48](#).
 - Capstan is positioned as shown in [Figure 48](#).
 - Clamps are located as shown in [Figure 48](#).
 - Clamps are positioned to avoid contacting any structures.
5. Mark locations for swage stops on bridle cable at outside edges of cable clamps.
6. Remove bridle cable clamps from bridle cable, and then remove capstan and cable guard from yaw servo (see Section [11.5](#) for instructions).
7. Slide a swage stop onto one end of bridle cable so it is aligned with mark on bridle cable.
8. Permanently attach swage stop to bridle cable, and then trim bridle cable end flush with outside edge of swage stop.
9. Repeat Steps 7 and 8 for opposite end of bridle cable.
10. Temporarily attach capstan and cable guard to yaw servo, as shown in [Figure 41](#). Cotter pin not required at this time.



Position servo capstan so orientation mark on capstan faces *toward* servo and is fully seated on servo disc. The capstan has a hole that fits over shear screw head.

11. Rotate capstan to locate orientation mark as shown in [Figure 48](#). Make sure bridle cable ends extend from capstan (see [Figure 48](#)).
12. Use bridle cable clamps to loosely connect bridle cable ends to rudder control cables, as shown in [Figure 48](#).
13. Make sure bridle cable does not contact cable guard.



The bridle cable will prematurely wear if it contacts the cable guard throughout its travel.

14. If cable guard interferes with bridle cable, adjust cable guard position (see Section [11.6: Cable Guard Adjustment](#)), and then repeat Step 13.
15. Tension and temporarily secure bridle cable to 15–20 lbs. Make sure capstan orientation mark points forward.



The tension on the bridle cable should never exceed the manufacturer's specified tension for the control cable.

16. When satisfied with tension and capstan position, tighten all bridle cable clamp nuts to 35-40 in-lb.
17. Use a feeler gauge to measure gaps between bridle cable clamp halves (top and bottom). Make sure gaps meet the following criteria:
 - Gap measurements on both sides of clamp are not less than 0.003" and not more than 0.050".



If clamp gap measurements do not meet criteria above, measure diameter of control cable, and then contact Dynon Technical Support for a resolution.

Out-of-specification cable clamps can slip under load.

18. Permanently attach capstan and cable guard to yaw servo (see Section 11.5 for instructions).

To check the yaw servo installation:

1. Release rudder.
2. Move rudder control through full range of motion per manufacturer's maintenance instructions, and verify the following:
 - Control is smooth throughout (i.e., no grinding, rubbing, or roughness).
 - Bridle cable clamps do not contact any structures during entire travel.
 - Capstan never rotates more than 150 degrees in either direction from neutral.
3. Cycle the control several times, return it to neutral, and verify the following:
 - Position of bridle cable clamps closely matches [Figure 48](#).
 - Capstan orientation mark is positioned as shown in [Figure 48](#).
 - Bridle cable tension has not changed.

8 Servo Electrical Connection

Refer to the following documents at dynoncertified.com/docs for complete electrical connection instructions:

- SkyView HDX System Installation Manual
- SkyView HDX Wiring Diagram - Twin Engine

Dynon provides the SV-NET-SERVO Network Autopilot Servo Cable Kit to aid in wiring the servos. Contact Dynon Sales for more information.



Servo electrical harnesses must be routed through the airframe structure as outlined in AC 43.13-1B, Chapter 11, Section 3.



Servo electrical harnesses must not chafe against airframe structure. After all electrical connection activities are complete, visually inspect all harness routing.



Servo electrical harnesses cannot interfere with the airplane's flight controls. After all electrical connection activities are complete, confirm this by moving all controls through full range of motion per manufacturer's maintenance instructions.



Terminate servo electrical harnesses with a D9 connector shell with female pins; terminate pigtails on servo electrical harnesses with mating D9 connectors.



Power for all servos must be controlled by a switch prominently mounted on the instrument panel labeled AP Power. This provides the pilot the ability to quickly turn off power to the servos should it be needed.



Servo power (AP Power) and the pitch and roll servo disconnect (AP DISC) circuits are required to be separate from the power and signal circuits provided over the SkyView Network. The servos should receive power from a common power source with circuit protection sized for the loads associated with all servos.



Do not connect the yaw servo disconnect circuit to the pitch and roll servo disconnect (AP DISC) circuit. This will result in a yaw servo calibration test failure. The yaw servo disconnect circuit should only be connected to a Yaw Damper button or left unconnected if no Yaw Damper button is installed.

After electrically connecting the Autopilot servos, perform the Servo Calibration Procedure (see Section [11.2: Calibration Procedure](#) for instructions).

8.1 Custom Wire Harness Preparation

If your SkyView Autopilot installation requires customized wire harnesses, refer to [Table 3](#) for wire/pin connection guidance. Dynon harness standard is to connect servo wires to a D9 male connector with threaded jack nuts. (See the *SkyView HDX Wiring Diagram - Single Engine* and *SkyView HDX System Installation Manual* documents at dynoncertified.com/docs for additional electrical installation information.)

Table 3: Autopilot Servo Harness, Pin/Wire Connections

D9 Harness Pin #	D9 Harness Wire Function	D9 Harness Wire Color	Connection / Notes
1	SkyView Network Data 1A	Green	SkyView Network D9 Connector, Pin 1
2	Ground	Black	Common Airframe Ground
3	Servo Disconnect	Yellow	Autopilot Disconnect Button or Yaw Damper Button
4	SkyView Network Data 2B	White w/ Blue	SkyView Network D9 Connector, Pin 4
5	None	No Wire	No Connection
6	SkyView Network Data 1B	Blue	SkyView Network D9 Connector, Pin 6
7	Power	Red	Electrical Bus Use 10A Circuit Breaker / Fuse
8	SkyView Network Data 2A	White w/ Green	SkyView Network D9 Connector, Pin 8
9	None	No Wire	No Connection

9 Electric Trim Control

Existing pitch trim motors certified for the airplane can be controlled through the SkyView HDX Autopilot system. Such trim motors must operate on 10–30 Volts with a maximum current draw of 5 Amps. This includes trim motors with or without a clutch.

Instructions for connecting to a trim motor, configuring SkyView HDX for trim control, and functionally testing the feature are found in the *103261-000 SkyView HDX System Installation Manual* document at dynoncertified.com/docs.

This page intentionally left blank.

10 Servo Troubleshooting

This section provides troubleshooting information for autopilot servos. See the *103221-000 SkyView HDX General Maintenance Manual* for information about troubleshooting the Autopilot system interface.

10.1 Servos Offline Messages

Condition:

One or more of the following messages appear on SkyView HDX display unit:

1. PITCH SERVO OFFLINE
2. ROLL SERVO OFFLINE
3. YAW SERVO OFFLINE

If all three messages annunciate:

1. Verify Master Power is *ON*.
2. Verify Autopilot circuit breaker and switch are *ON*.
3. Verify all harness connectors for all servos are properly mated.
4. Verify electrical power to all servos.
5. Verify adequate ground quality for all servos.

If condition persists, or if only one message annunciates:

1. Enter SETUP menu (hold Buttons #7 and #8)
2. Enter SYSTEM SETUP -> SKYVIEW NETWORK SETUP-> NETWORK STATUS
3. Locate the SV32/SV42 devices (servos) in list of network devices. If necessary, use knobs to scroll through entire list. If you do not see a servo entry in the list of network devices for each servo installed, press BACK button, and perform a SkyView Network Configuration.
4. If any servos are highlighted in RED:
 - A. Verify Autopilot circuit breaker and switch are *ON*.
 - B. Inspect/fix wiring to affected servo, or common wiring if multiple servos are offline.
5. If any servos are highlighted in YELLOW, a software upgrade did not complete properly.
6. If all above fails, contact Dynon technical support. Always have a properly rated mechanic or qualified facility remove unit.

10.2 Servo Slip Messages

Condition:

One or more of the following messages appear and persist on SkyView HDX display unit:

1. PITCH SERVO SLIP
2. ROLL SERVO SLIP
3. YAW SERVO SLIP

The momentary appearance of SERVO SLIP messages is expected due to certain weather conditions during Autopilot operation. If a SERVO SLIP message persists, contact Dynon Technical Support for assistance.

10.3 Abnormal Operation

Condition:

One or more Autopilot axes fail to move as expected or operate in an unexpected manner.

To test for bridle cable clamp slippage:

1. On ground, engage the Autopilot into Level Mode.
2. From exterior of the airplane, grasp, and gently attempt to move the affected control surface (i.e., elevator, aileron, rudder).
3. Have an assistant observe the bridle cable clamps during Step #2.
4. If cable clamp slips, remove and install the clamp per guidance in Section [11.8](#), [11.9](#), or [11.10](#).

To test for broken shear screw:

1. On ground, engage the Autopilot into Level Mode.
2. From exterior of the airplane, grasp, and gently attempt to move the affected control surface (i.e., elevator, aileron, rudder).
3. If Autopilot does not resist attempt to move control surface, contact Dynon Technical Support to request a 102991-000 Shear Screw Replacement Kit.

11 Servo Maintenance

This section provides maintenance information for autopilot servos and associated bracketry. See the *103221-000 SkyView HDX General Maintenance Manual* for information about troubleshooting the Autopilot system interface.



No special tools or facility are required to service autopilot servos and associated bracketry.

11.1 Service

Every 12 months (1 calendar year), the autopilot servo components and wiring harnesses should be inspected to ensure continued integrity of the installation (see below).

- Inspect for security of servo attachment, which includes visual inspection of brackets and other supporting structures that attach to the airplane.
- Inspect for signs of corrosion.
- Inspect condition of wiring, shield terminations, routing, and attachment/clamping, along with any airplane penetration points.

In the event of system failures, contact Dynon technical support. Always have a properly rated mechanic or qualified facility remove a failed component.

11.2 Calibration Procedure

The SkyView HDX Autopilot servo settings are available for download as a configuration file that is loaded into the SkyView HDX display. This file configures the autopilot servo performance settings to meet the applicable certification regulations. Servo calibration cannot be performed without the following:

- An ADAHRS module (SV-ADAHRS-200) installed and configured in the SkyView network.
- All servos installed and configured in the SkyView network.
- V-speeds correctly entered in SkyView HDX. (See the *SkyView HDX System Installation Manual* document for instructions.)

To make a new servo appear on the SkyView HDX display, configure the SkyView network (SYSTEM SETUP > NETWORK SETUP > CONFIGURE). (See the *SkyView HDX System Installation Manual* document for instructions.)

To calibrate the servos, enter the Servo Calibration Wizard (SETUP MENU > HARDWARE CALIBRATION > AP SERVO CALIBRATION > CALIBRATION) and follow the onscreen instructions to calibrate the servo(s).

SkyView HDX checks the status of the AP Disengage Button. If SkyView HDX detects that the button is pressed (the input is grounded) upon entering AP SERVO CALIBRATION, the AP

Disengage Button is assumed to be stuck (or incorrectly installed), resulting in the following message being displayed, and the Autopilot servo calibration is aborted:

"The servo disconnect switch appears to be pressed and may be installed incorrectly. The servo disconnect switch should be a type Momentary, Push Button Normal Open (PBNO). Press cancel below to return to the servo calibration menu."

If the servo calibration procedure is not successful, inspect the button and servo wiring. (See the 103261-000 SkyView HDX System Installation Manual document for instructions.) If button type and wiring is correct, call Dynon Technical Support.

If the servo calibration procedure is successful, SkyView HDX will automatically instruct you to run the servo test procedure. (See Section 11.3 for instructions.)

11.3 Test Procedure

The servo test procedure requires a successful servo calibration. The servo test procedure verifies that each servo is configured properly by moving the control surfaces while the installer verifies the correct movement. You may run this procedure on its own at any time after a successful servo calibration. SkyView HDX will not display AP status on the Top Bar until after this test procedure is successfully completed.

To run this procedure on its own (after a successful servo calibration procedure), enter the Servo Test Wizard (SETUP MENU > HARDWARE CALIBRATION > AP SERVO CALIBRATION > TEST) and follow the onscreen instructions to test the servo(s).

11.4 Servo Operation Check

Complete the following procedures to confirm the autopilot servos are operating correctly.

To check the pitch and roll axes:

1. Make sure master power and Autopilot servo power are *ON*.
2. Center, and lightly hold in place, flight control yoke.
3. Align HDG/TRK bug with current heading.
4. Select ALT and HDG.
5. Engage Autopilot.
6. Set Vertical Speed +1000.
7. Set Altitude 1000 feet above current.

Yoke should move in Nose Up direction.

8. Press and hold ALT button to return Altitude bug to current.

Yoke should move back to neutral position.

9. Change HDG/TRK bug to right of current heading.

Yoke should move in direction of a right roll.

-
10. Change HDG/TRK bug to left of current heading.

Yoke should move in direction of a left roll.

To check the yaw axis:

1. Make sure master power and Autopilot servo power are *ON*.
2. Move rudder pedals left and right to feel operation.
3. Center, and lightly hold in place, rudder pedals.
4. Engage Yaw Damper.
5. Move rudder pedals to the Left.

Rudder pedals should encounter some resistance to movement. The servo may slip. Resistance by the servo indicates the system is operating normally.

6. Move rudder pedals to the right.

Rudder pedals should encounter some resistance to movement. The servo may slip. Resistance by the servo indicates the system is operating normally.

7. Disconnect Yaw Damper.
8. Move rudder pedals left and right to feel operation.

Resistance should not occur.

To check Autopilot disconnect:

1. Make sure master power and Autopilot servo power are *ON*.
2. Engage Autopilot.
3. Complete the following:
 - Press AP button in Autopilot Control menu, and make sure Autopilot disconnects.
"AUTOPILOT DISCONNECT" aural indication should be heard.
 - Turn AP Servo Power switch *OFF*, and make sure Autopilot disconnects.
"AUTOPILOT DISCONNECT" aural indication should be heard.
 - If installed, press AP button on Autopilot Control Panel, and make sure Autopilot disconnects.
"AUTOPILOT DISCONNECT" aural indication should be heard.
 - If installed, press panel-mounted Autopilot Disconnect button, and make sure Autopilot disconnects.
"AUTOPILOT DISCONNECT" aural indication should be heard.
 - If installed, press yoke-mounted Autopilot Disconnect button, and make sure Autopilot disconnects.

"AUTOPILOT DISCONNECT" aural indication should be heard.

11.5 Servo Capstan Removal and Attachment

Dynon's autopilot servos are shipped with capstans installed. Servo installation procedures often require the temporary removal and re-attachment of capstans.



Unless otherwise specified, torque all fasteners per specifications in AC 43.13-1B, Table 7-1. Include specified friction drag value when torquing screws.

Reference [Figure 50: Exploded View of a Typical Servo Capstan Assembly](#) when performing the following procedure.

To remove and re-attach the capstan:

1. Remove cotter pin that secures castle nut to servo shaft.
2. Mark position of castle nut in relation to servo shaft, and then remove castle nut from servo shaft.
3. Remove wave washer from servo shaft.
4. Removed nylon washer from servo shaft.
5. Remove capstan from servo shaft.



The shear screw does not need to be removed from the servo disc. The capstan has a hole that fits over the shear screw head.



If the shear screw is loosened, it must be completely removed and replaced (see Section [11.7: Shear Screw Replacement](#)).

6. Place capstan onto output shaft, aligning hole in capstan with shear screw head located in servo disc.
7. Replace nylon washer on servo shaft.
8. Replace wave washer on servo shaft.
9. Finger-tighten castle nut onto servo shaft, and then use a wrench to tighten until slot in castle nut lines up with hole for cotter pin in servo shaft.



DO NOT overtighten the castle nut!

Tightening the castle nut beyond 4 in-lbs may prevent the capstan from rotating freely in the event of shear screw failure.

10. Install new cotter pin to secure castle nut to servo shaft.

11.6 Cable Guard Adjustment

Dynon's autopilot servos are shipped with cable guards installed. The cable guard may need to be repositioned to avoid interference with the flight control cables or the bridle cables during servo installation procedures. The following procedure details the task of adjusting a cable guard.



Unless otherwise specified, torque all fasteners per specifications in AC 43.13-1B, Table 7-1. Include specified friction drag value when torquing screws.

Reference [Figure 50: Exploded View of a Typical Servo Capstan Assembly](#) when performing the following procedure.

To adjust the cable guard:

1. Remove capstan from servo shaft (see Section [11.5](#) for instructions).
2. Remove screws and washers that secure capstan guard to servo.
3. Rotate capstan guard to correct position.
4. Secure capstan guard to servo with screws and washers.
5. Re-attach capstan to servo shaft (see Section [11.5](#) for instructions).

11.7 Shear Screw Replacement

Dynon autopilot servos come equipped with a capstan. The capstan connects to the servo via a frangible shear screw. The shear screw can be broken by the pilot to restore system movement should a servo become jammed. It is possible for turbulence loads acting on the airplane to cause a shear screw to fail, even though the servo never jammed.



In the event of a shear screw failure, contact Dynon Technical Support to request a 102991-000 Shear Screw Replacement Kit.



Shear screw replacement instructions are provided in the *Dynon Servo Shear Screw Replacement Instructions* document included in the Shear Screw Replacement Kit.

11.8 Roll Servo Removal and Replacement

This section provides instructions for removing and replacing a roll servo and connecting it back to the control system.

The roll servo and bracketry are installed in the fuselage on the forward, left-hand side of the Rear Spar Carry Through near FS118.5 (see [Figure 1](#) for exact location). To install the roll servo, installers need to access this area in accordance with the manufacturer's service manual. See [Figure 11](#) for an example of a complete installation.



Make sure all flight control cables are rigged and tensioned in accordance with manufacturer's instructions.



Always disconnect aircraft battery before starting removal and installation activities.



Unless otherwise specified, torque all fasteners per specifications in AC 43.13-1B, Table 7-1. Include specified friction drag value when torquing screws.

To remove the roll servo:

1. Disconnect D9 cable harness connector from servo.
2. Mark locations of bridle cable clamps on aileron control cable.



Securing (e.g., taping) the bridle cable to capstan grooves prevents cable from unraveling when handling.

3. Loosen bridle cable clamps.
4. Unfasten hardware that secures roll servo bracket assembly to forward support bracket and rear spar bracket (see [Figure 12](#)). Retain hardware for installation.
5. Remove capstan (with bridle cable) and cable guard from roll servo (see [Section 11.5](#) for instructions).



DO NOT loosen or remove the shear screw from the servo disc!

6. Remove safety wiring from roll servo bolts.
7. Unfasten hardware that secures roll servo to plate bracket (see [Figure 3](#)). Retain hardware for installation.
8. Remove roll servo from plate bracket.

To replace the roll servo:

1. Secure ailerons in center of travel.
2. Secure roll servo to plate bracket, as shown in [Figure 3](#).
3. Safety wire roll servo bolts (see [Figure 11](#) for example).
4. Temporarily attach capstan to roll servo, as shown in [Figure 13](#). Finger-tighten castle nut, and tighten, but do not torque, other hardware. Cotter pin and washers not needed yet.



Position servo capstan so orientation mark on capstan faces *away from* servo and is fully seated on servo disc. The capstan has a hole that fits over shear screw head.

5. Place roll servo bracket assembly into aircraft, as shown in [Figure 5](#) and [Figure 6](#). Make sure aileron control cable is on top of assembly and to rear of servo capstan.



Positioning of servo capstan in relation to aileron control cable in height and distance is critical for an airworthy installation.

6. Secure roll servo bracket assembly to forward support bracket and rear spar bracket, as shown in [Figure 12](#).
7. Rotate capstan to locate swage engagement hole on opposite side of capstan from aileron control cable. Make sure bridle cable ends extend from capstan, as shown in [Figure 14](#) or [Figure 15](#).
8. Make sure aileron control cable in area where bridle cable clamps will attach is clean and free of dirt and grease.
9. Use bridle cable clamps to loosely connect bridle cable ends to aileron control cable at marks made during removal process. Make sure clamps contact swage stops at each end of bridle cable, as shown in [Figure 14](#) or [Figure 15](#).
10. Make sure bridle cable does not contact cable guard.



The bridle cable will prematurely wear if it contacts the cable guard throughout its travel.

11. If cable guard interferes with bridle cable, adjust cable guard position (see [Section 11.6](#) for instructions), and then repeat Step 10.
12. Tension and temporarily secure bridle cable to 15–20 lbs. Make sure swage engagement hole is on opposite side of capstan from aileron control cable.



The tension on the bridle cable should never exceed the tension on control cable.

13. When satisfied with tension and capstan position, tighten all bridle cable clamp nuts to 35-40 in-lb.

14. Use a feeler gauge to measure gaps between bridle cable clamp halves (top and bottom). Make sure gaps meet the following criteria:

- Gap measurements on both sides of clamp are not less than 0.003" and not more than 0.050".



If clamp gap measurements do not meet criteria above, measure diameter of control cable, and then contact Dynon Technical Support for a resolution.

Out-of-specification clamps can slip under load.

15. Permanently attach capstan and cable guard to roll servo (see Section 11.5 for instructions).

16. Connect D9 cable harness connector to servo.

To check the roll servo installation:

1. Release ailerons.
2. Move aileron control through full range of motion per manufacturer's maintenance instructions, and verify the following:
 - Control is smooth throughout (i.e., no grinding, rubbing, or roughness).
 - Bridle cable clamps do not contact any structures during entire travel.
 - Capstan never rotates more than 150 degrees in either direction from neutral.
3. Cycle the control several times, return it to neutral, and verify the following:
 - Position of bridle cable clamps closely matches [Figure 14](#) or [Figure 15](#).
 - Capstan orientation mark is positioned as shown in [Figure 14](#) or [Figure 15](#).
 - Bridle cable tension has not changed.



After all Autopilot servos have been serviced, perform servo calibration procedure (see Section 5.3 [Servo Calibration Procedure](#) for instructions).

11.9 Pitch Servo Removal and Replacement

This section provides instructions for removing and replacing a pitch servo and connecting it back to the control system.

The pitch servo and bracketry are in the fuselage, behind the frame at FS207 (see [Figure 17](#) for exact location). To service the pitch servo, technicians need to remove the FS170 access panel located behind the baggage area in accordance with the manufacturer's service manual.



Make sure all flight control cables are rigged and tensioned in accordance with manufacturer's instructions.



Always disconnect aircraft battery before starting removal and installation activities.



Unless otherwise specified, torque all fasteners per specifications in AC 43.13-1B, Table 7-1. Include specified friction drag value when torquing screws.

To remove the pitch servo:

1. Disconnect D9 cable harness connector from servo.
2. Mark locations of bridle cable clamps on elevator control cable.



Securing (e.g., taping) the bridle cable to capstan grooves prevents cable from unraveling when handling.

3. Loosen bridle cable clamps.
4. Remove capstan (with bridle cable) and cable guard from pitch servo (see [Section 11.5](#) for instructions).



DO NOT loosen or remove the shear screw from the servo disc!

5. Remove safety wiring from pitch servo bolts.
6. Unfasten hardware that secures pitch servo to shelf bracket (see [Figure 25](#) or [Figure 28](#)). Retain hardware for installation.
7. Remove pitch servo from shelf bracket.

To replace the pitch servo:

1. Secure elevator in center of travel.
2. Permanently secure pitch servo to bracket, as shown in see [Figure 25](#) or [Figure 28](#).
3. Safety wire roll servo bolts (see [Figure 26](#) or [Figure 30](#) for example).
4. Temporarily attach capstan (with bridle cable) and cable guard to pitch servo, as shown in [Figure 31](#) or [Figure 32](#).



Position servo capstan so orientation mark on capstan faces *toward* servo and is fully seated on servo disc. The capstan has a hole that fits over shear screw head.

5. Rotate capstan to locate swage engagement hole on opposite side of capstan from elevator control cable. Make sure bridle cable ends extend from capstan, as shown in [Figure 33](#).
6. Make sure elevator control cable in area where bridle cable clamps will attach is clean and free of dirt and grease.
7. Use bridle cable clamps to loosely connect bridle cable ends to elevator control cable at marks made during removal process. Make sure clamps contact swage stops at each end of bridle cable, as shown in [Figure 33](#).
8. Make sure bridle cable does not contact cable guard.



The bridle cable will prematurely wear if it contacts the cable guard throughout its travel.

9. If cable guard interferes with bridle cable, adjust cable guard position (see Section [11.6](#) for instructions), and then repeat Step 8.
10. Tension and temporarily secure bridle cable to 15–20 lbs. Make sure swage engagement hole is on opposite side of capstan from elevator up cable.



The tension on the bridle cable should never exceed the tension on control cable.

11. When satisfied with tension and capstan position, tighten all bridle cable clamp nuts to 35-40 in-lb.
12. Use a feeler gauge to measure gaps between bridle cable clamp halves (top and bottom). Make sure gaps meet the following criteria:
 - Gap measurements on both sides of clamp are not less than 0.003" and not more than 0.050".



If clamp gap measurements do not meet criteria above, measure diameter of control cable, and then contact Dynon Technical Support for a resolution.

Out-of-specification clamps can slip under load.

13. Permanently attach capstan and cable guard to pitch servo (see Section [11.5](#) for instructions).
14. Connect D9 cable harness connector to servo.

To check the pitch servo installation:

1. Release elevator.
2. Move elevator control through full range of motion, and verify the following:
 - Control is smooth throughout (i.e., no grinding, rubbing, or roughness).
 - Bridle cable clamps do not contact any structures during entire travel.
 - Capstan never rotates more than 150 degrees in either direction from neutral.
3. Cycle the control several times, return it to neutral, and verify the following:
 - Position of bridle cable clamps closely match dimensions shown in [Figure 33](#).
 - Swage engagement hole is on same side of capstan as control cable.
 - Bridle cable tension has not changed.



After all Autopilot servos have been serviced, perform servo calibration procedure (see Section [5.3 Servo Calibration Procedure](#) for instructions).

11.10 Yaw Servo Removal and Replacement

This section provides instructions for removing and replacing a yaw servo and connecting it back to the control system.

The yaw servo and bracketry are in the fuselage, behind the frame at FS207 (see [Figure 17](#) for exact location). To service the yaw servo, technicians need to remove the FS170 access panel located behind the baggage area in accordance with the manufacturer's service manual.



Make sure all flight control cables are rigged and tensioned in accordance with manufacturer's instructions.



Always disconnect aircraft battery before starting removal and installation activities.



Unless otherwise specified, torque all fasteners per specifications in AC 43.13-1B, Table 7-1. Include specified friction drag value when torquing screws.

To remove the yaw servo:

1. Disconnect D9 cable harness connector from servo.
2. Remove bracket assembly braces, as shown in [Figure 47](#).
3. Remove boxing plate, as shown in [Figure 38](#).
4. Mark locations of cable clamps on rudder control cables.



Securing (e.g., taping) the bridle cable to capstan grooves prevents cable from unraveling when handling.

5. Loosen bridle cable clamps.
6. Remove capstan (with bridle cable) and cable guard from yaw servo (see [Section 11.5](#) for instructions).



DO NOT remove the shear screw from the servo disc!

7. Remove safety wiring from yaw servo bolts.
8. Unfasten hardware that secures yaw servo to bridge bracket (see [Figure 35](#)). Retain hardware for installation.
9. Remove yaw servo from bridge bracket.

To replace the yaw servo:

1. Secure rudder in center of travel.
2. Permanently secure yaw servo to bridge bracket, as shown in [Figure 35](#).
3. Safety wire yaw servo bolts (see [Figure 37](#) for example).
4. Temporarily attach capstan (with bridle cable) and cable guard to yaw servo, as shown in [Figure 41](#).



Position servo capstan so orientation mark on capstan faces *toward* servo and is fully seated on servo disc. The capstan has a hole that fits over shear screw head.

5. Rotate capstan to locate orientation mark as shown in [Figure 48](#). Make sure bridle cable ends extend from capstan (see [Figure 48](#)).
6. Make sure rudder control cables in area where bridle cable clamps will attach is clean and free of dirt and grease.
7. Use bridle cable clamps to loosely connect bridle cable ends to rudder control cables at marks made during removal process. Make sure bridle cable travels over roller and cable clamps contact swage stops at each end of bridle cable, as shown in [Figure 48](#).
8. Make sure bridle cable does not contact cable guard.



The bridle cable will prematurely wear if it contacts the cable guard throughout its travel.

9. If cable guard interferes with bridle cable, adjust cable guard position (see Section [11.6](#) for instructions), and then repeat Step 8.
10. Tension and temporarily secure bridle cable to 15–20 lbs. Make sure orientation mark points forward (see [Figure 48](#)).



The tension on the bridle cable should never exceed the tension on control cable.

11. When satisfied with tension and capstan position, tighten all bridle cable clamp nuts to 35-40 in-lb.
12. Use a feeler gauge to measure gaps between bridle cable clamp halves (top and bottom). Make sure gaps meet the following criteria:
 - Gap measurements on both sides of clamp are not less than 0.003" and not more than 0.050".



If clamp gap measurements do not meet criteria above, measure diameter of control cable, and then contact Dynon Technical Support for a resolution.

Out-of-specification clamps can slip under load.

13. Permanently attach capstan and cable guard to yaw servo (see Section [11.5](#) for instructions).

14. Permanently secure boxing plate, as shown in [Figure 38](#).
15. Permanently secure bracket assembly braces, as shown in [Figure 47](#).
16. Connect D9 cable harness connector to servo.

To check the yaw servo installation:

1. Release rudder.
2. Move rudder control through full range of motion per manufacturer's maintenance instructions, and verify the following:
 - Control is smooth throughout (i.e., no grinding, rubbing, or roughness).
 - Bridle cable clamps do not contact any structures during entire travel.
 - Capstan never rotates more than 150 degrees in either direction from neutral.
3. Cycle the control several times, return it to neutral, and verify the following:
 - Position of bridle cable clamps closely matches [Figure 48](#).
 - Capstan orientation mark is positioned as shown in [Figure 48](#).
 - Bridle cable tension has not changed.



After all Autopilot servos have been serviced, perform servo calibration procedure (see Section [5.3 Servo Calibration Procedure](#) for instructions).

12 Figures

12.1 Roll Servo Figures

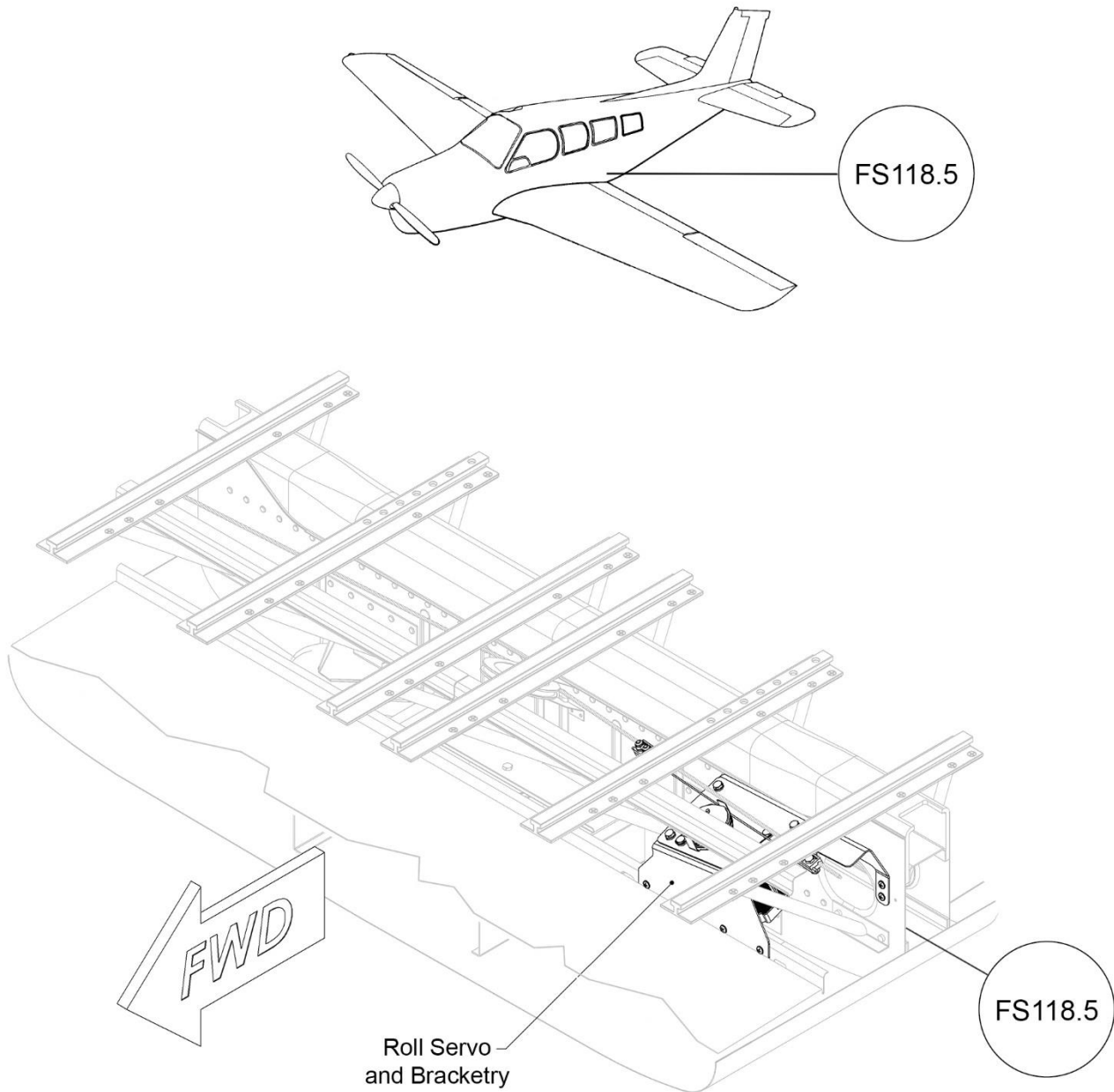

Figure 1: Roll Servo Location

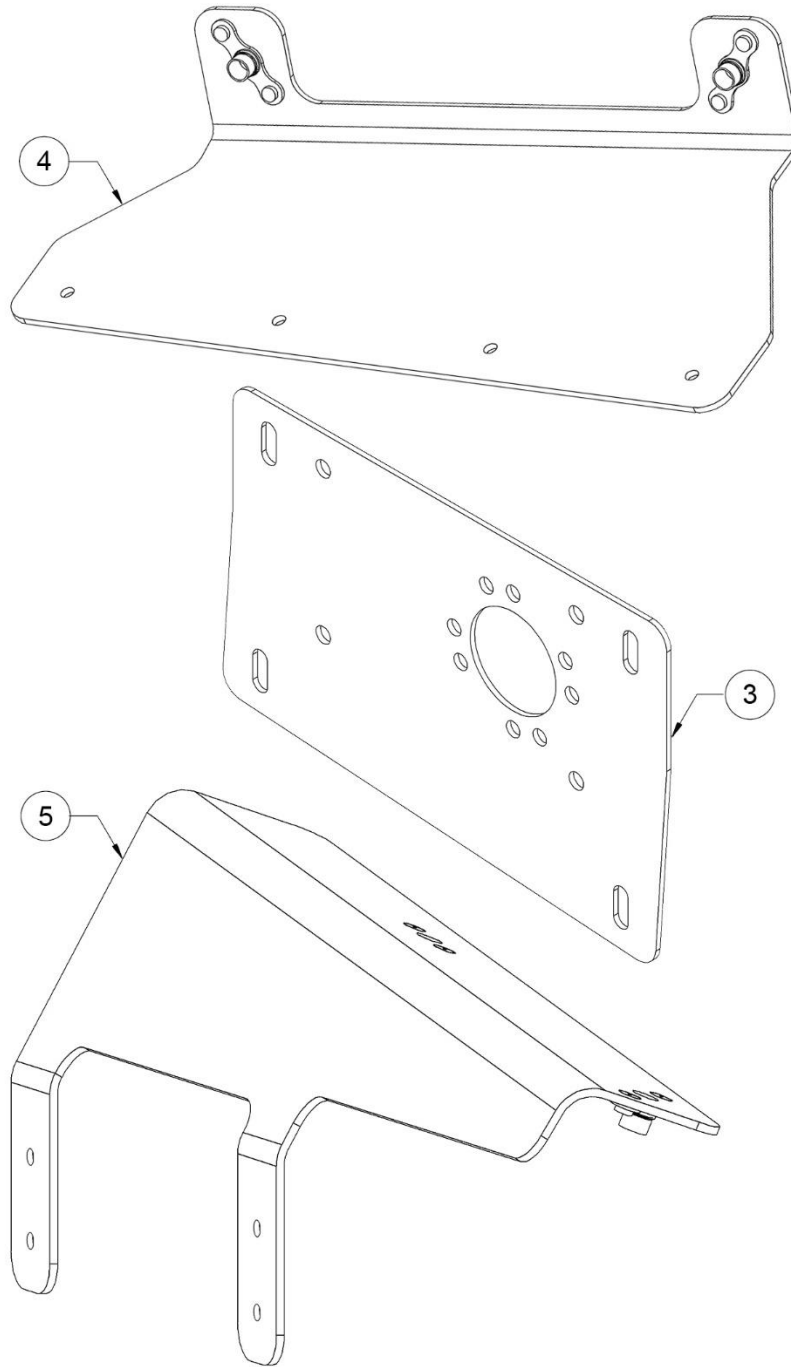

Figure 2: Roll Servo Bracketry

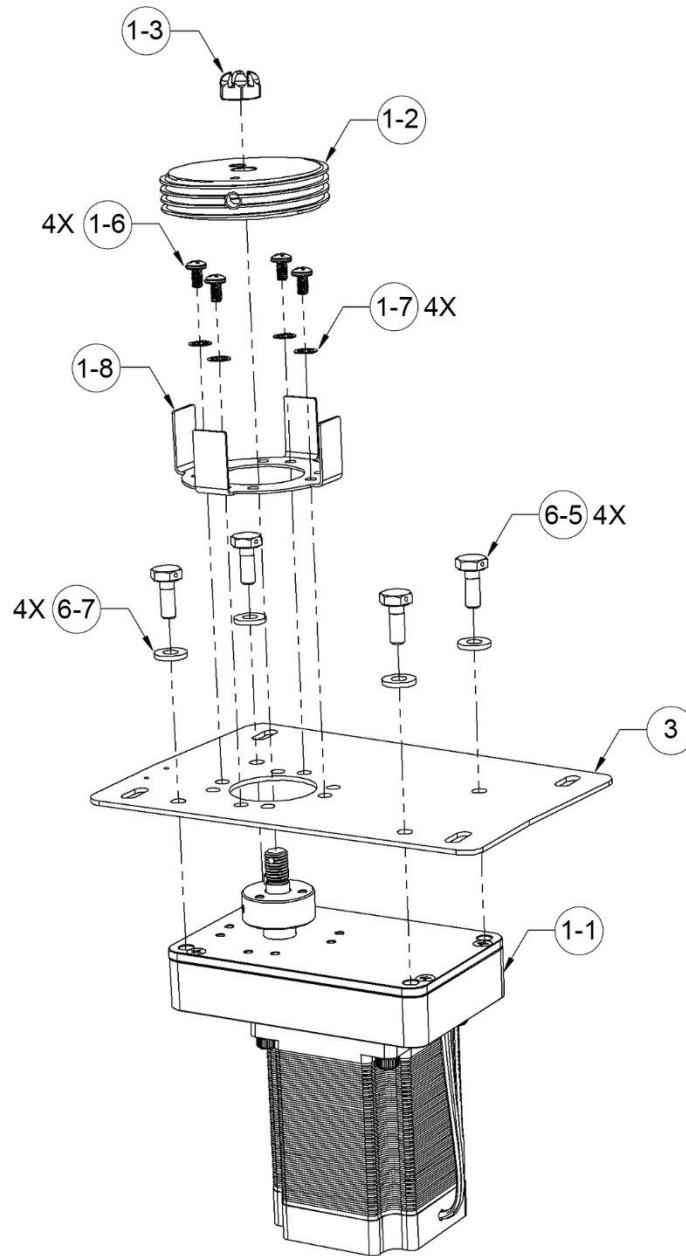

Figure 3: Attaching Roll Servo to Plate Bracket

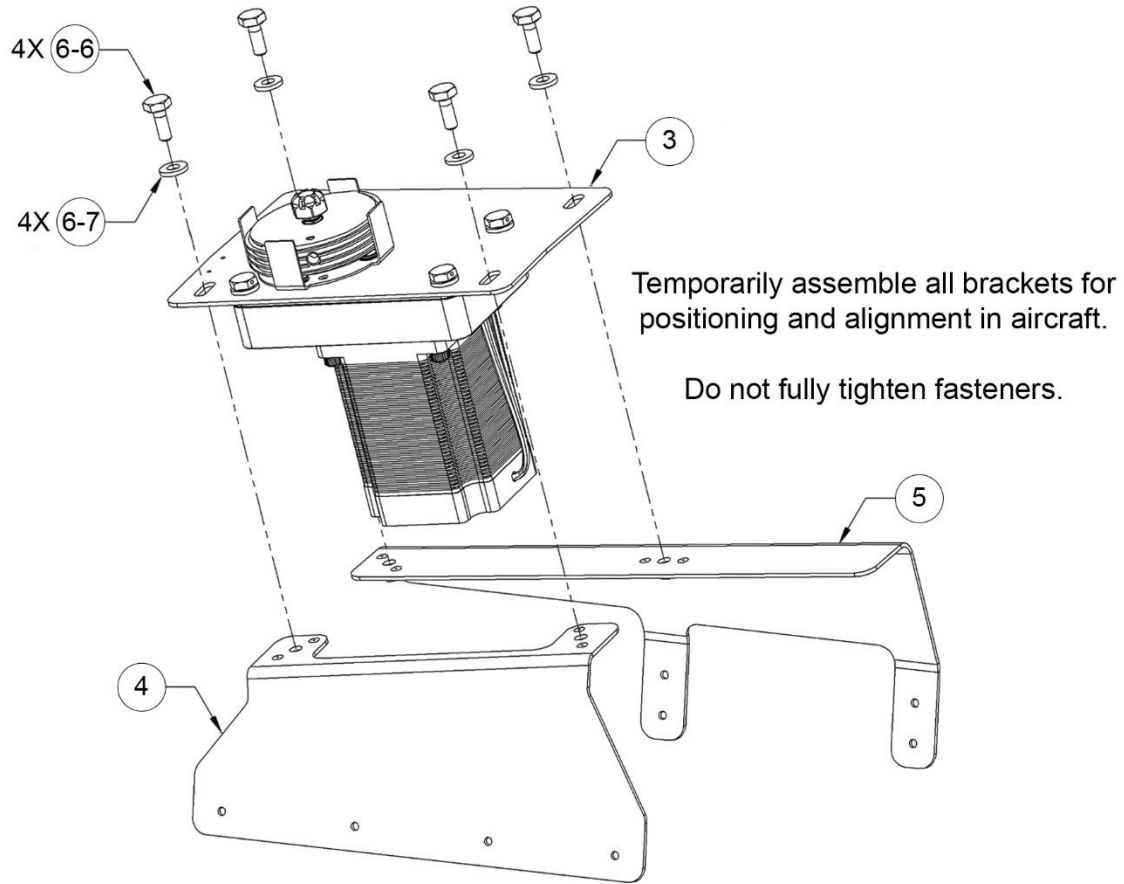

Figure 4: Attaching Plate Bracket (with Roll Servo) to Support Brackets

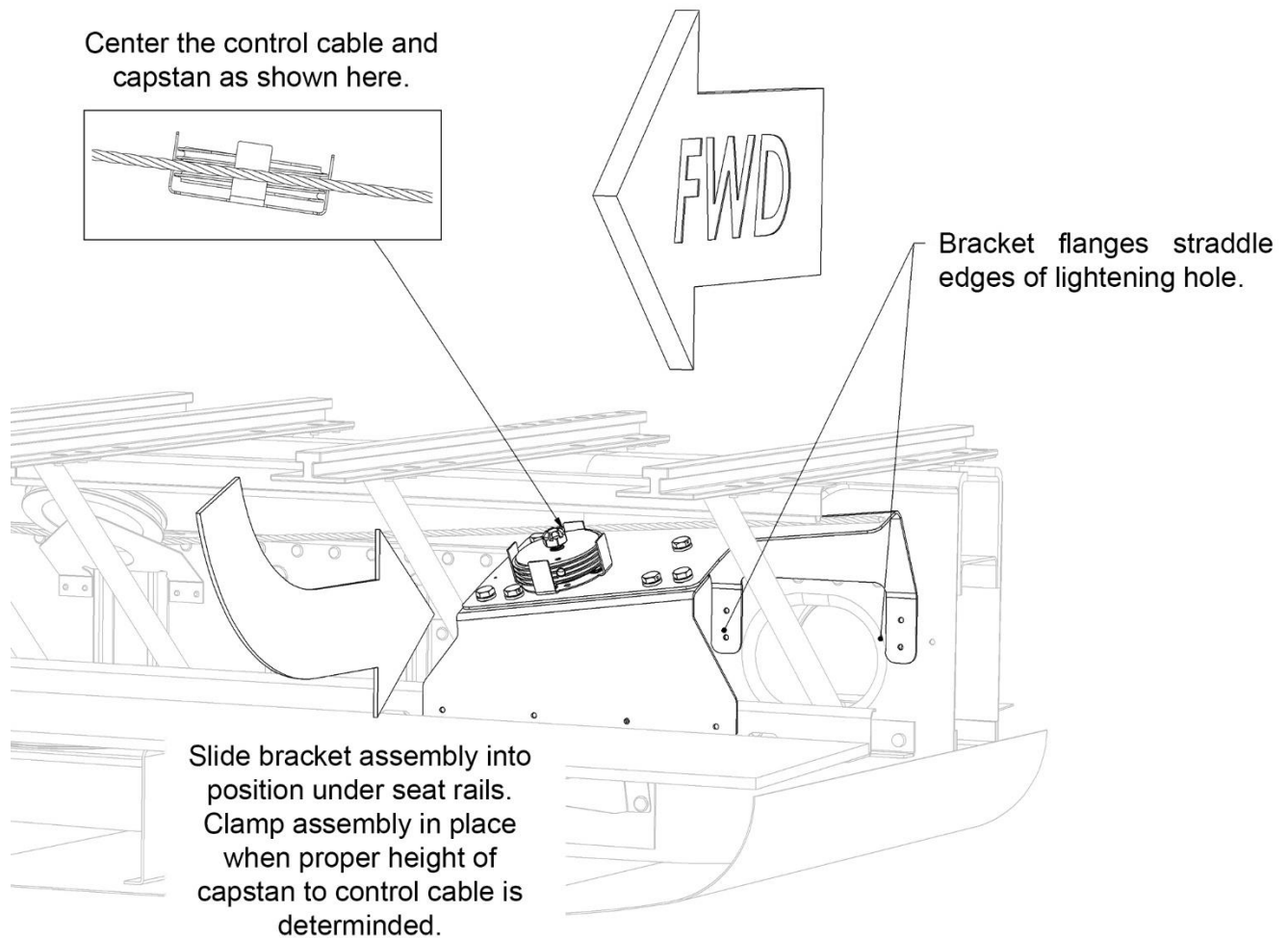

Figure 5: Positioning Roll Servo Bracket Assembly

LOOKING DOWN PERPENDICULAR TO CAPSTAN

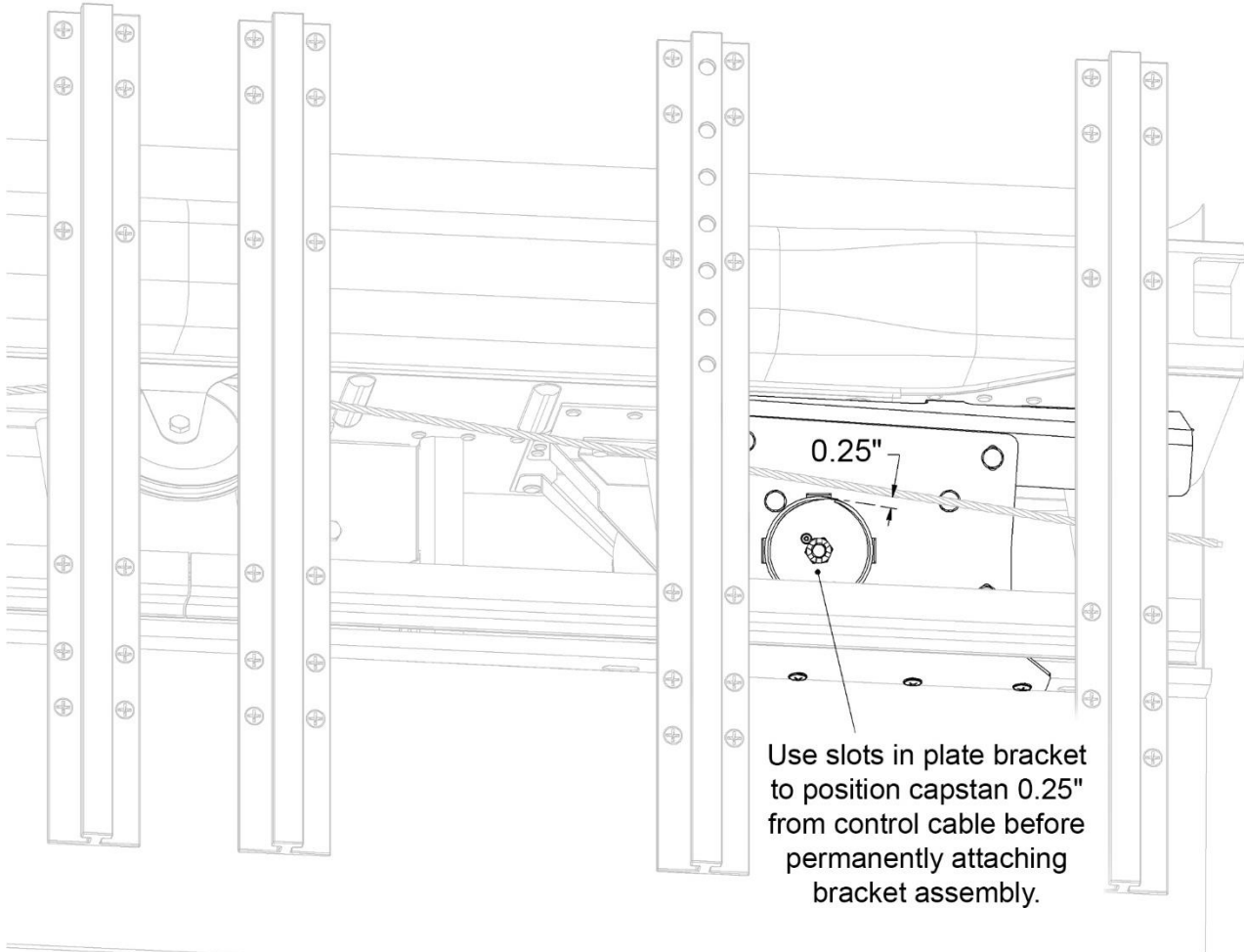

Figure 6: Positioning Capstan in Relation to Aileron Control Cable

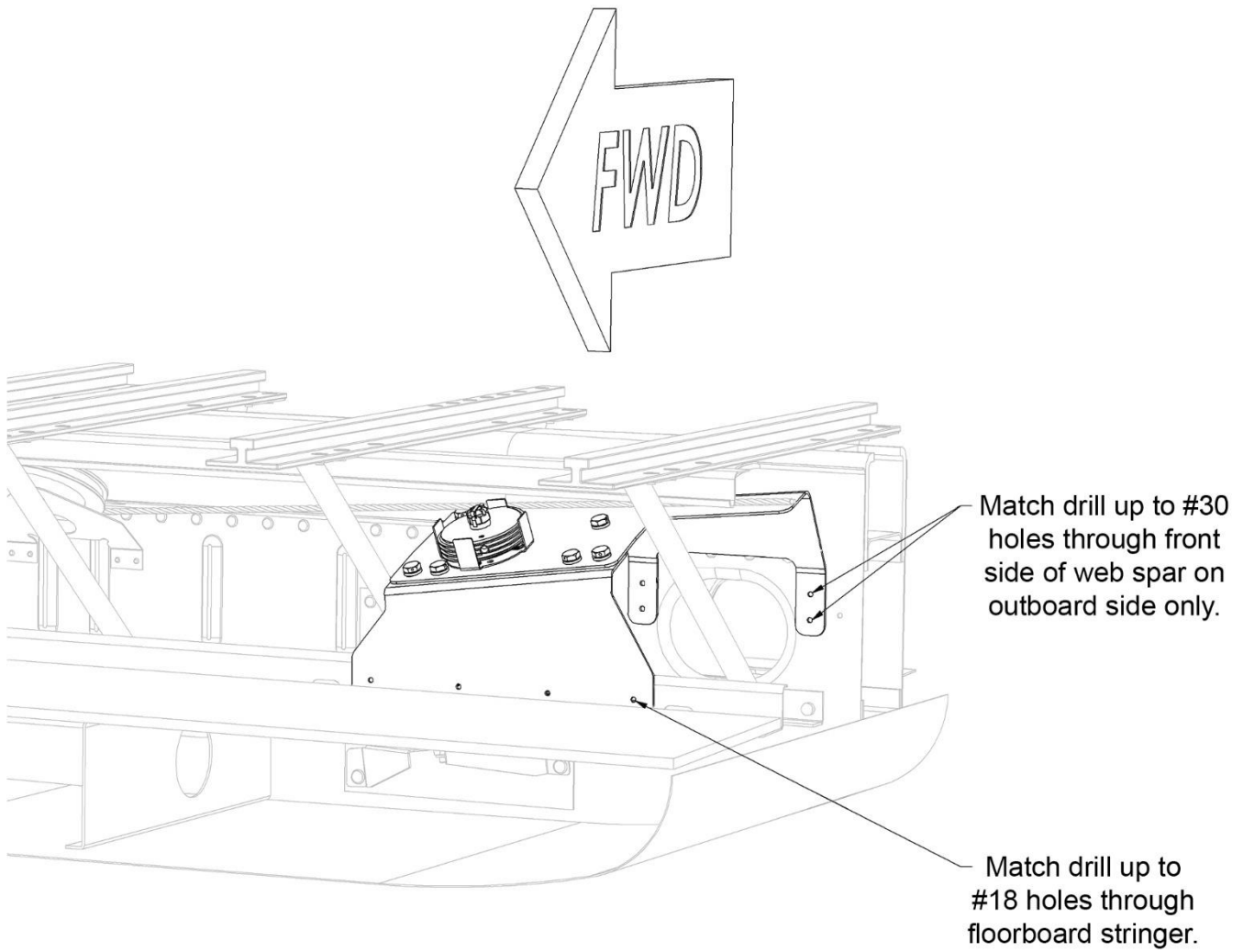

Figure 7: Drilling Holes for Roll Servo Brackets

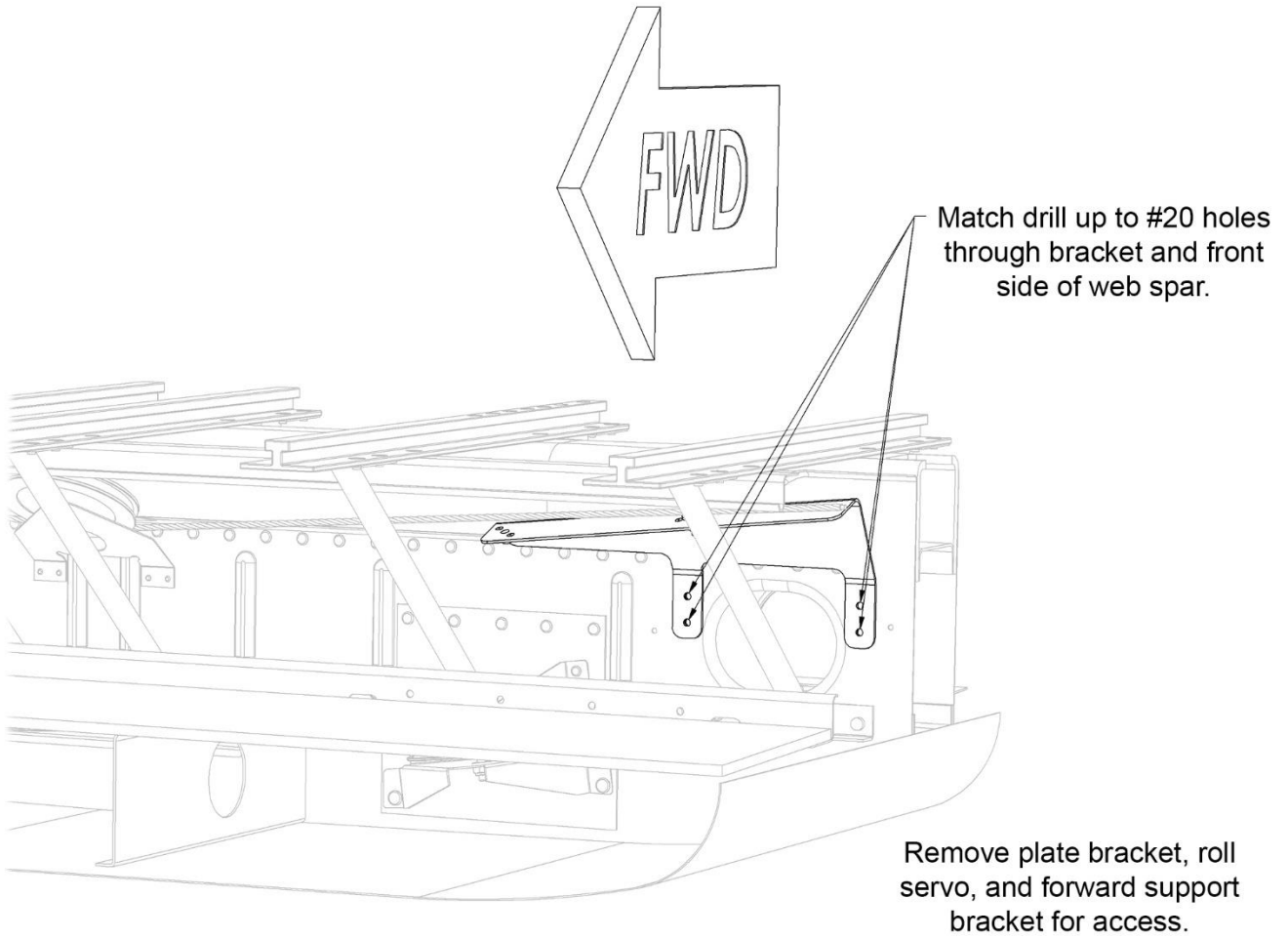
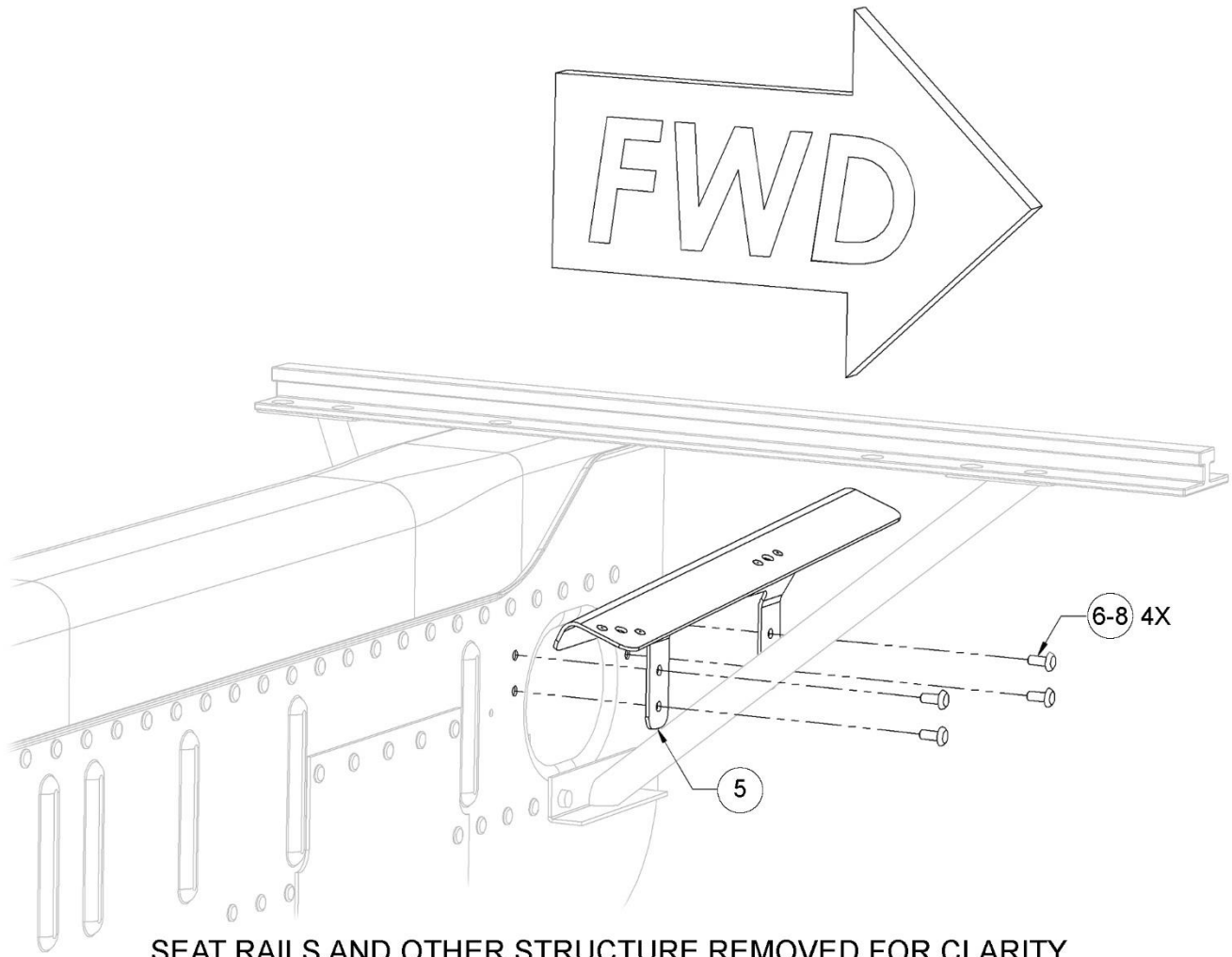

Figure 8: Drilling Holes for Rear Spar Bracket



SEAT RAILS AND OTHER STRUCTURE REMOVED FOR CLARITY

Figure 9: Securing Rear Spar Bracket

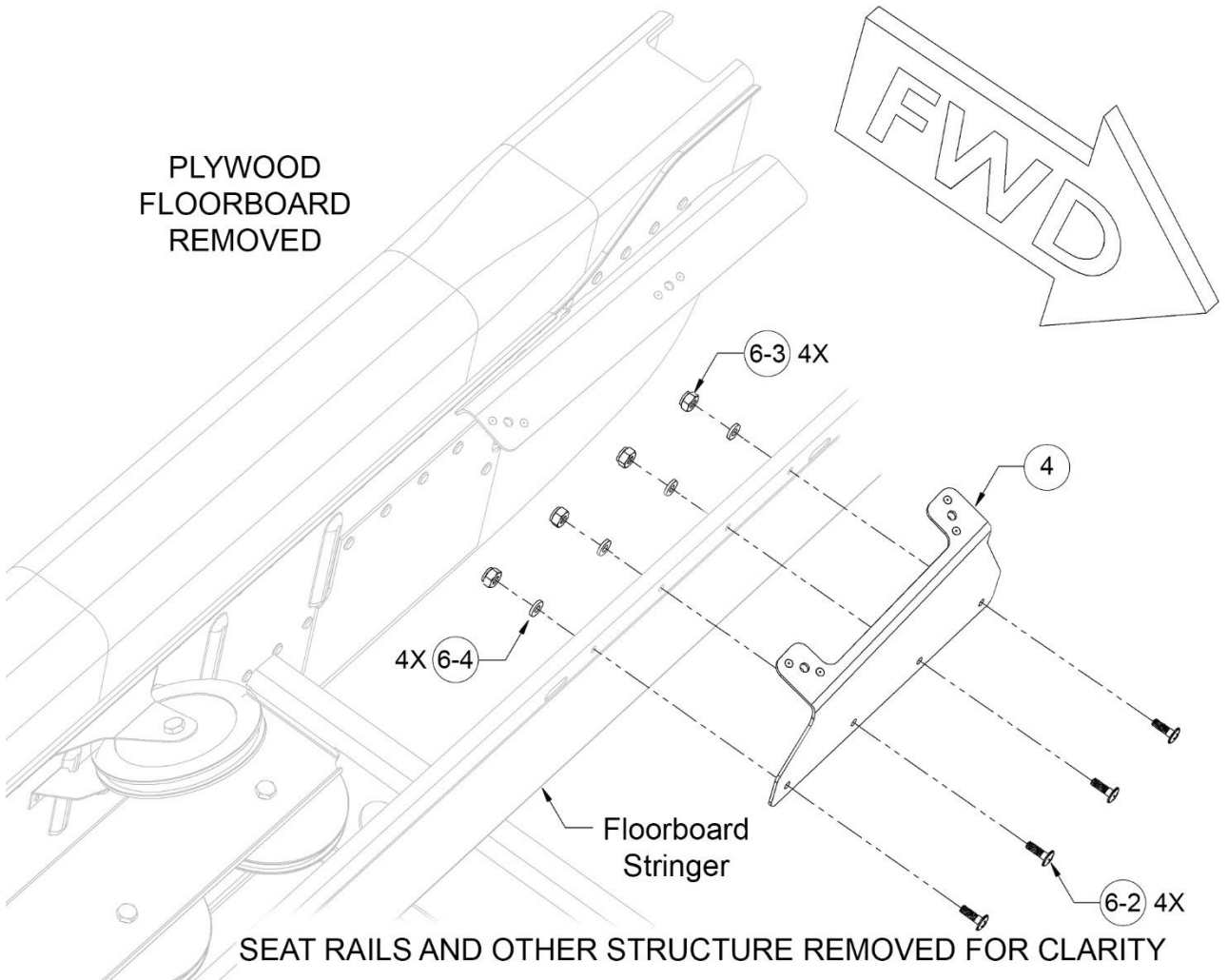

Figure 10: Securing Forward Support Bracket

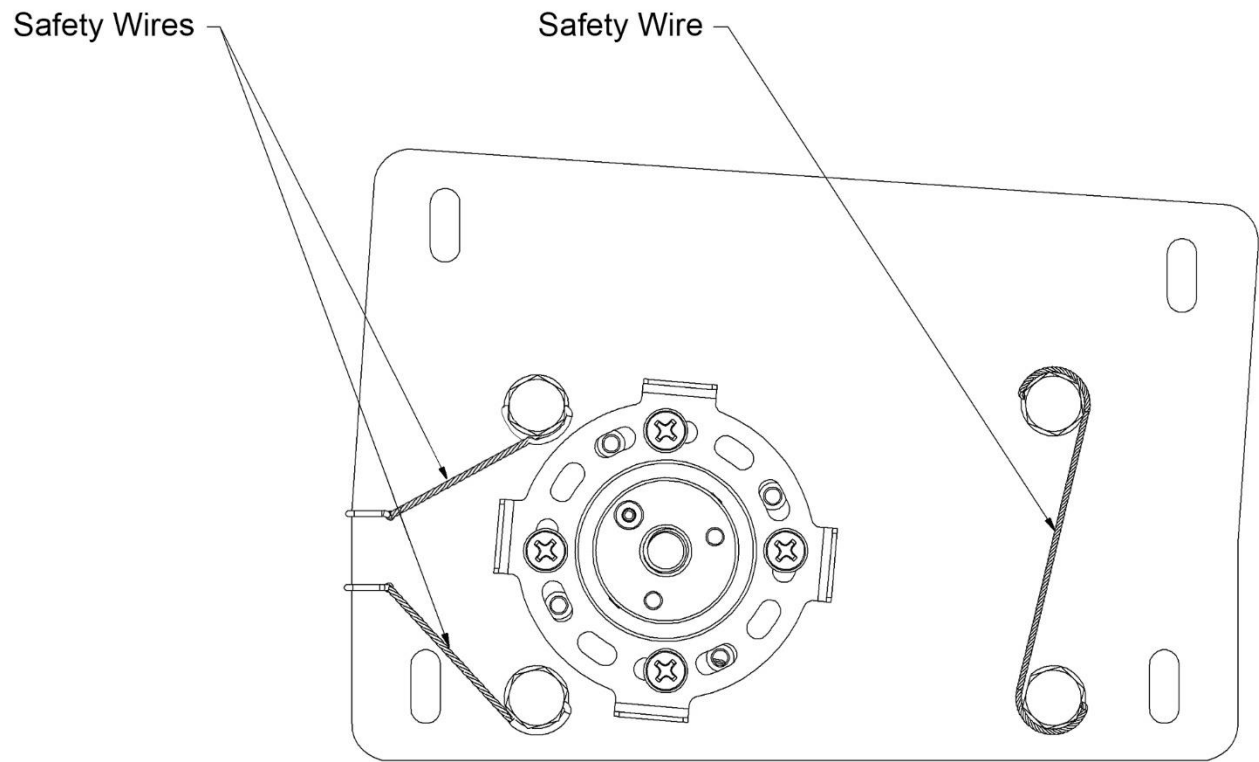
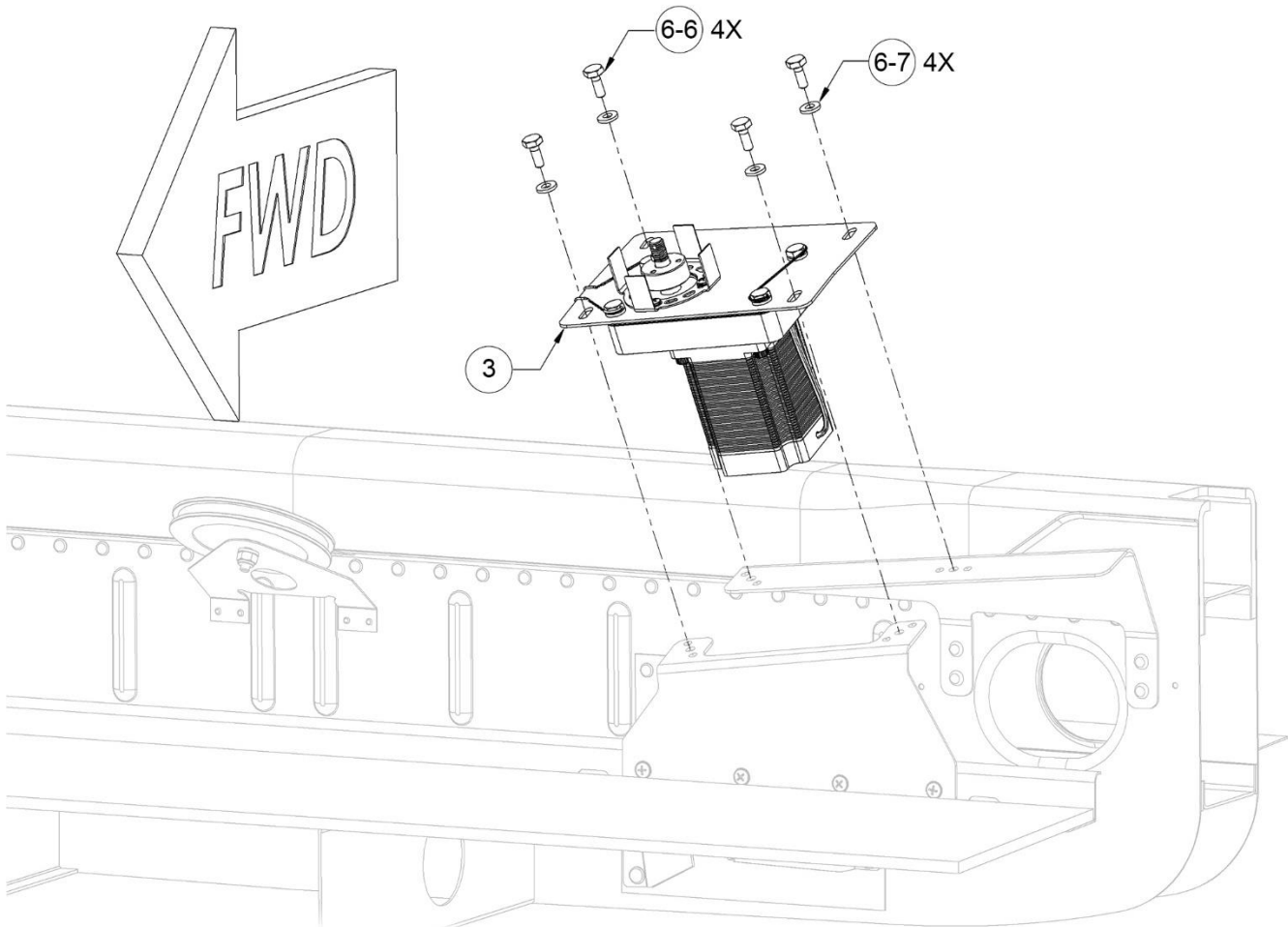
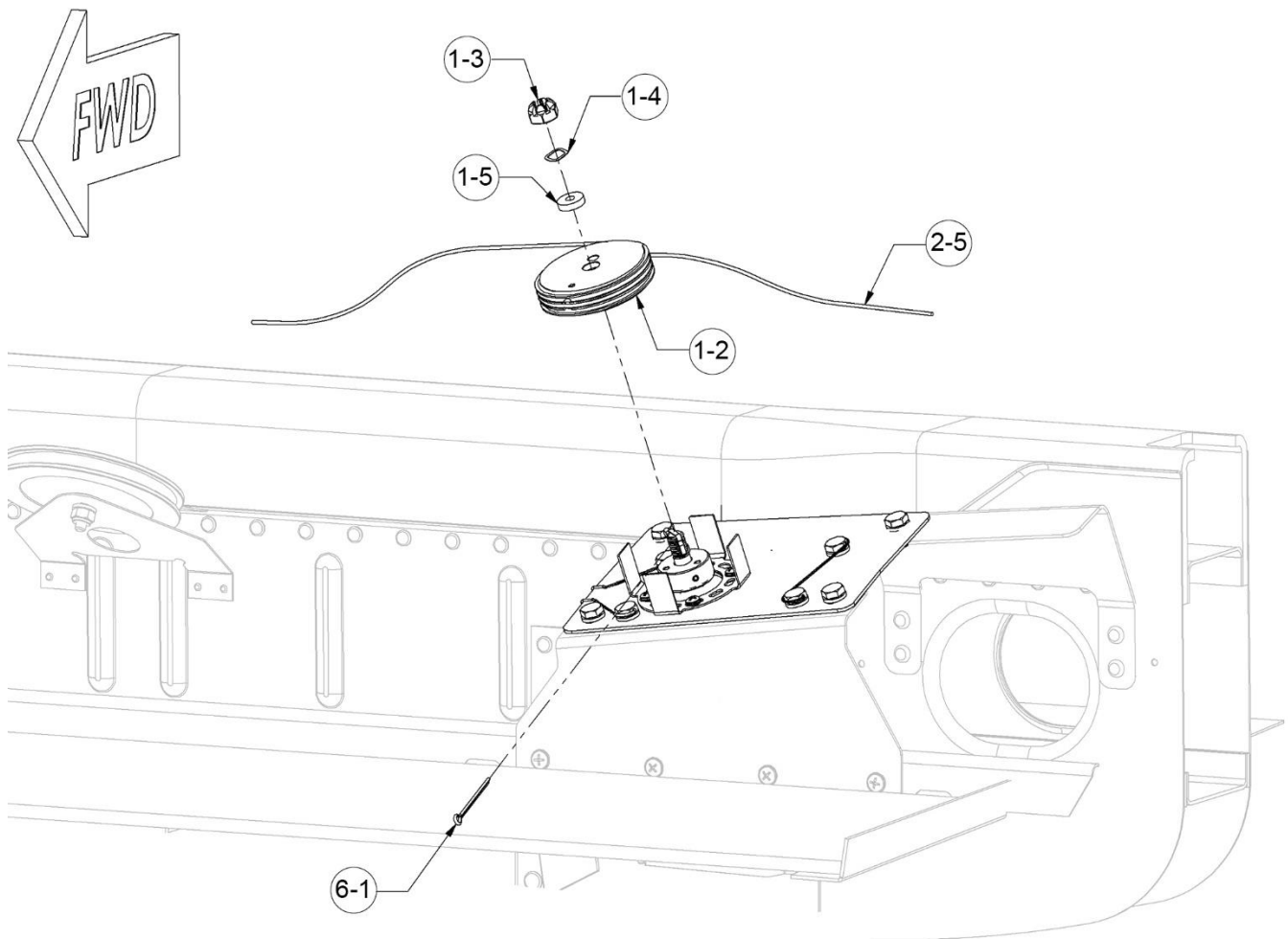

Figure 11: Safety Wiring Roll Servo Bolts (Example)



SEAT RAILS AND OTHER STRUCTURE REMOVED FOR CLARITY

Figure 12: Securing Plate Bracket (with Roll Servo)



SEAT RAILS AND OTHER STRUCTURE REMOVED FOR CLARITY

Figure 13: Installing Capstan with Bridle Cable

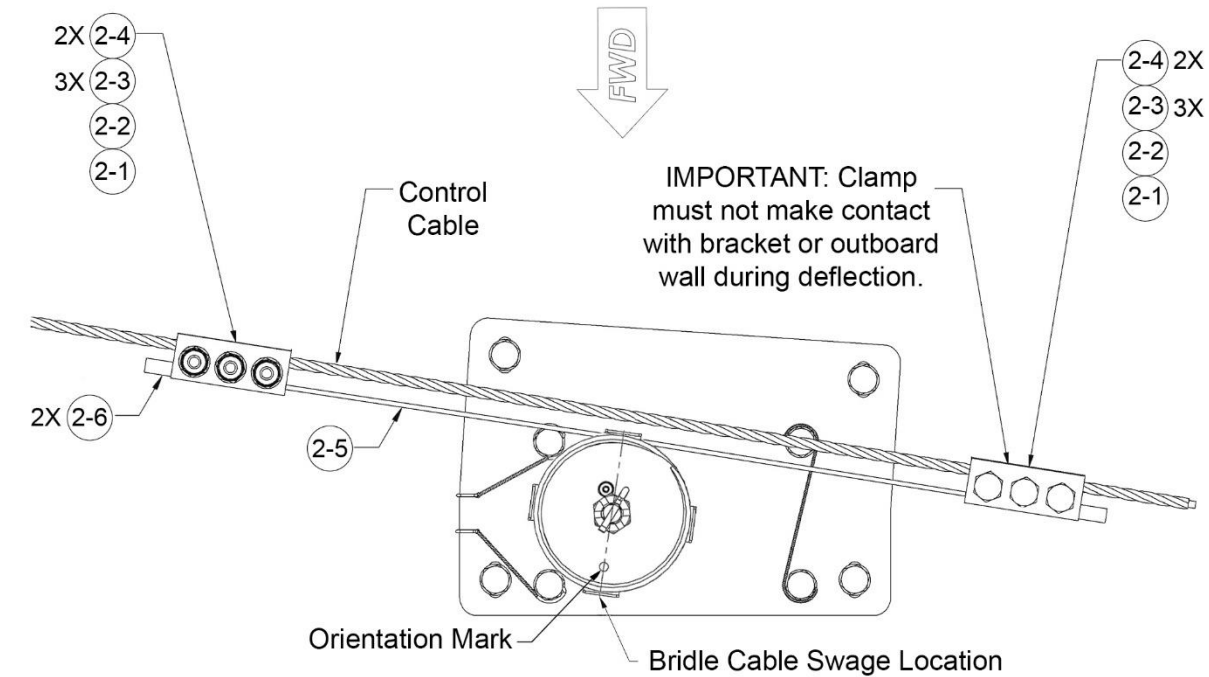

STRUCTURE REMOVED FOR CLARITY

Figure 14: Installing Roll Servo Bridle Cable and Clamps – Outboard of Turnbuckle

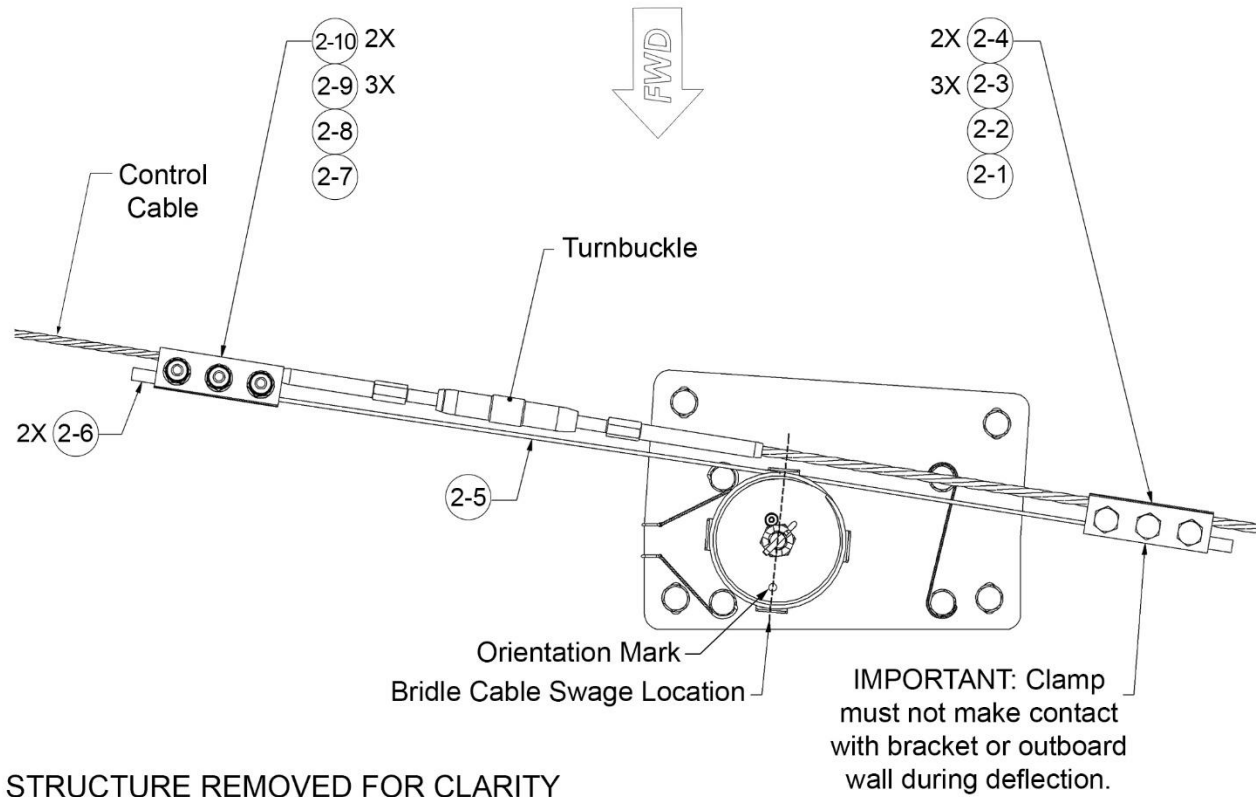

STRUCTURE REMOVED FOR CLARITY

Figure 15: Installing Roll Servo Bridle Cable and Clamps – Inboard of Turnbuckle

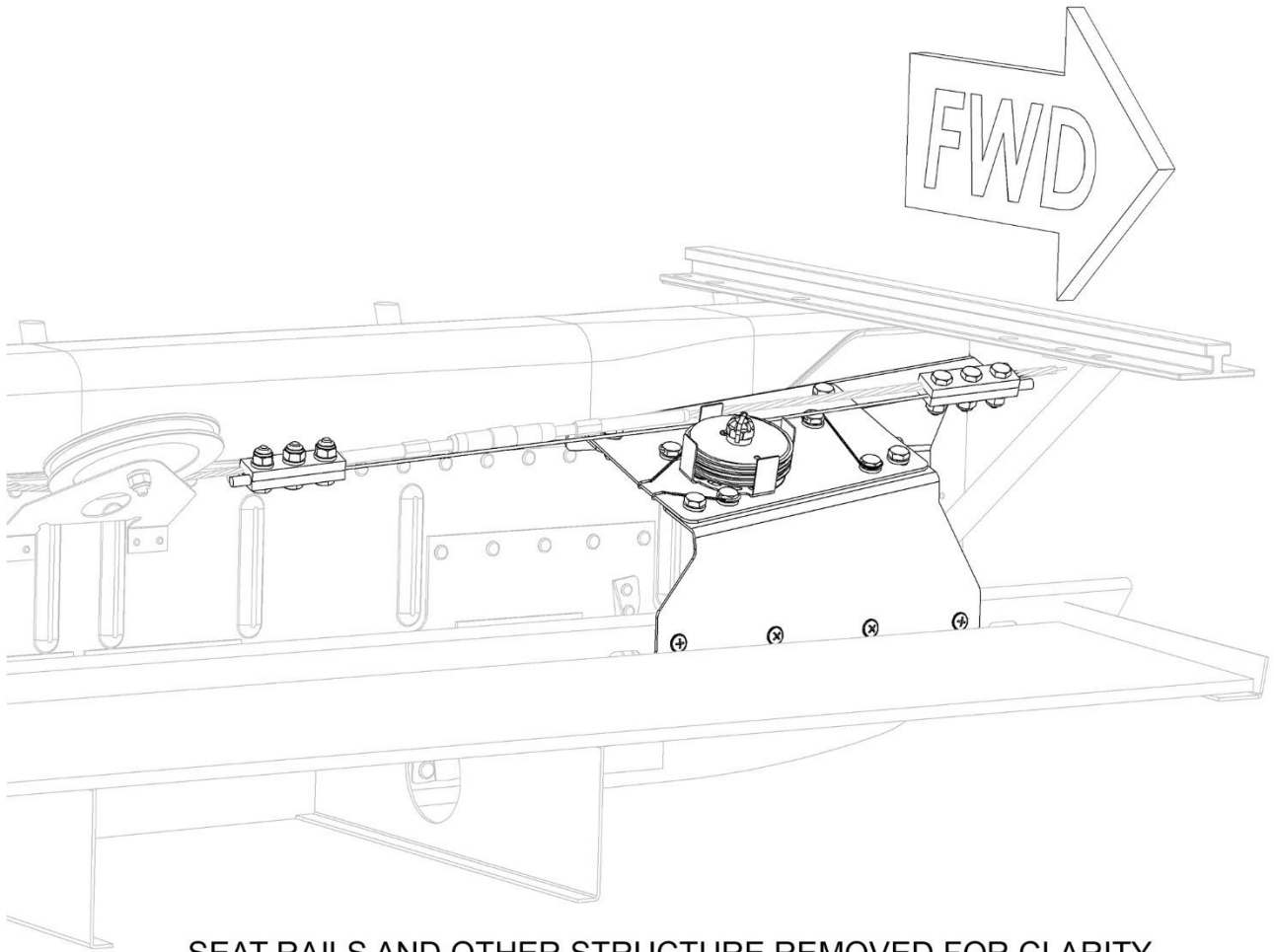

SEAT RAILS AND OTHER STRUCTURE REMOVED FOR CLARITY

Figure 16: Roll Servo – Complete Installation

12.2 Pitch Servo Figures

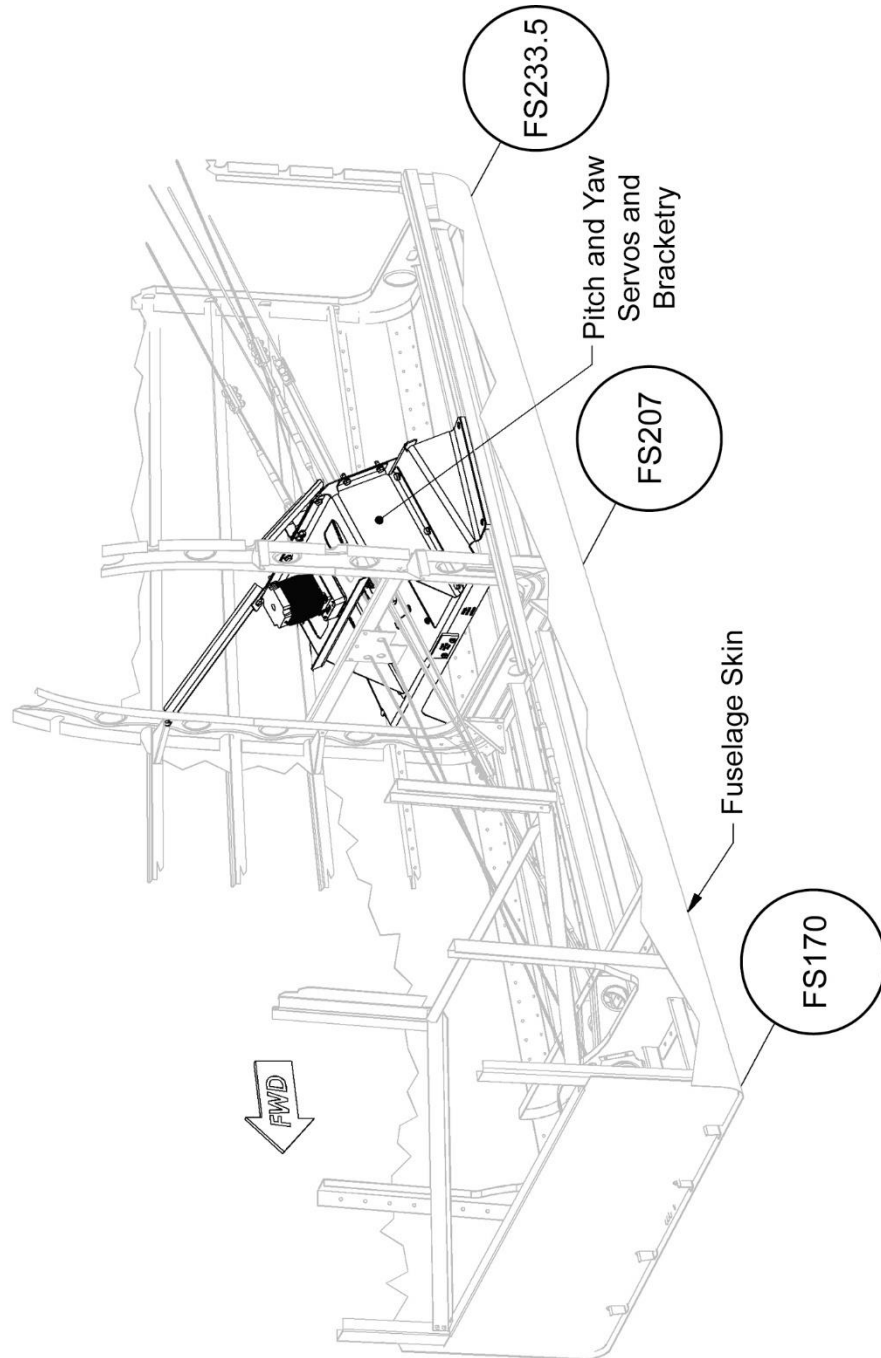

Figure 17: Pitch and Yaw Servo Locations

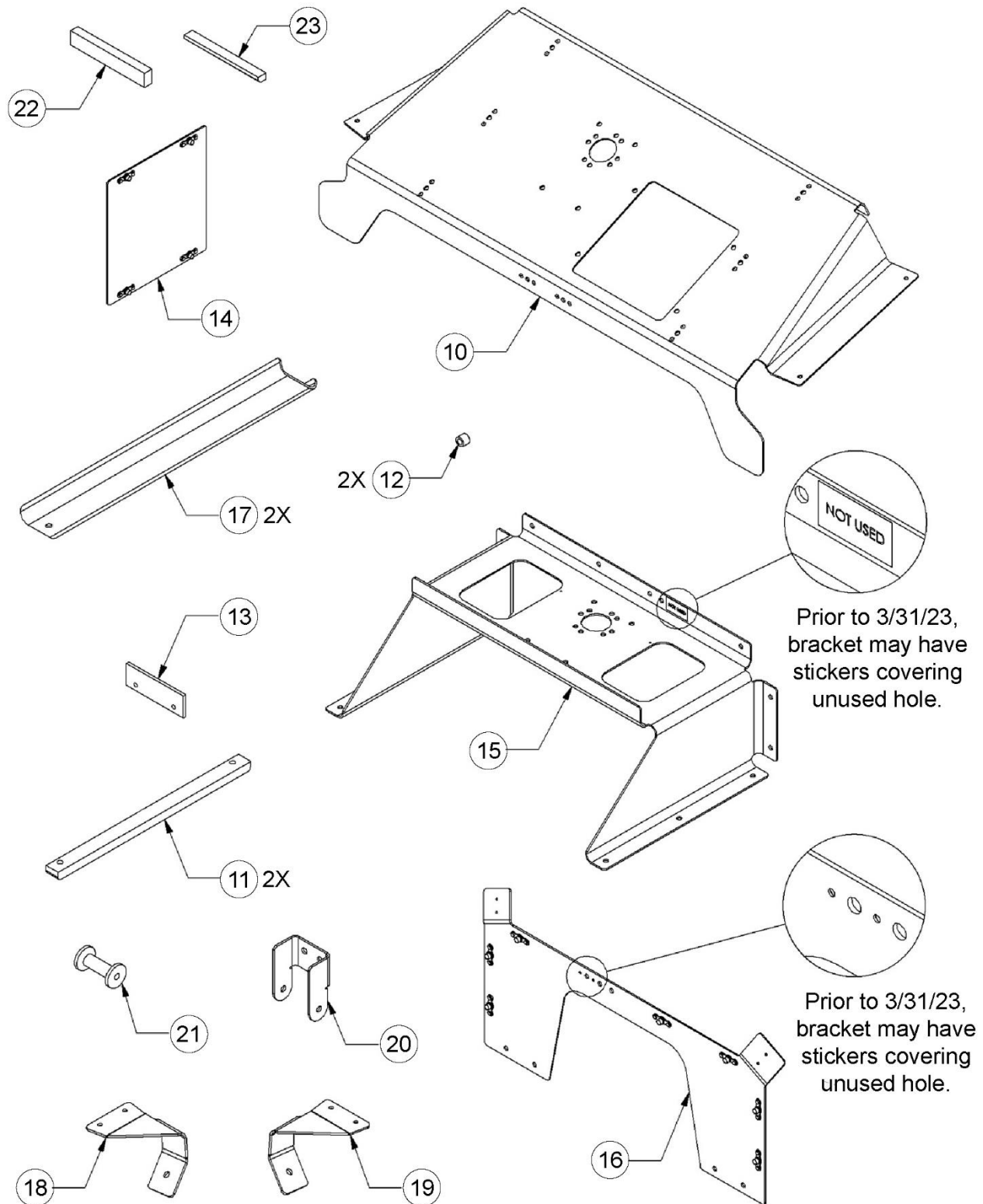

Figure 18: Pitch and Yaw Servo Bracketry

S/N # E1-E571 Only

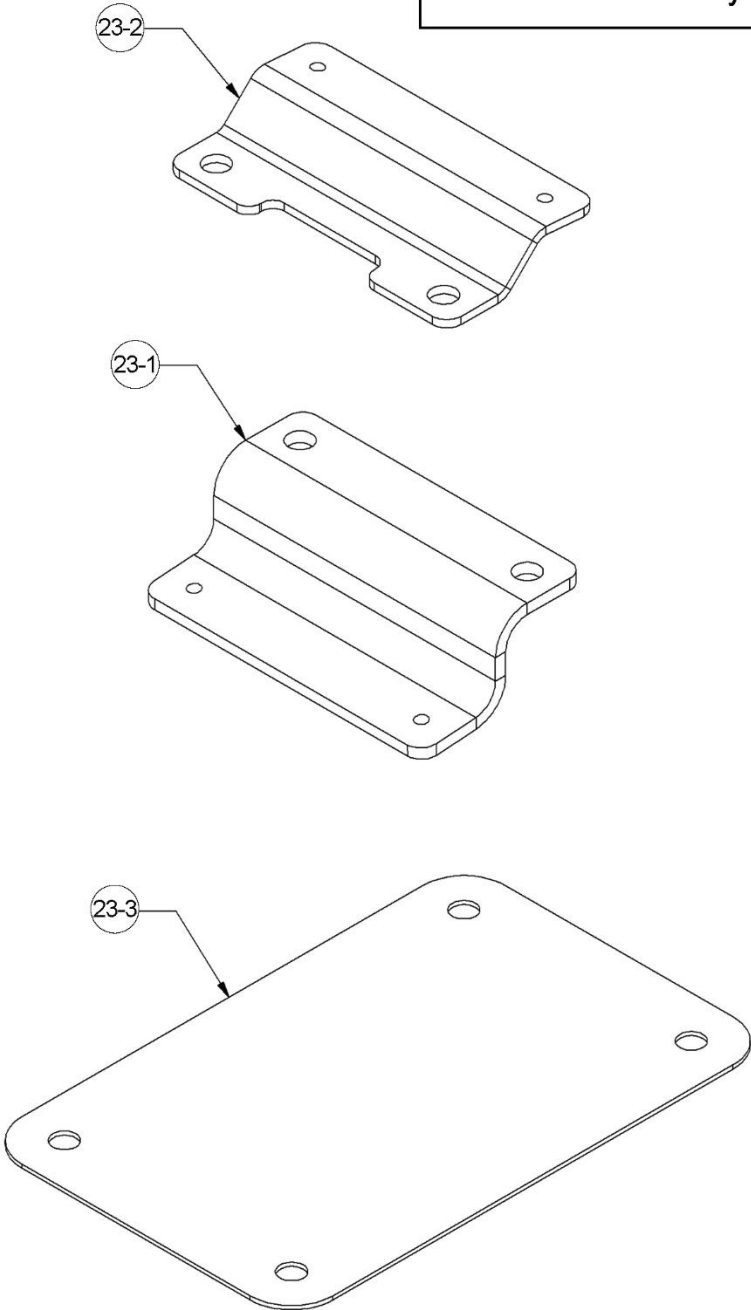

Figure 19: Additional Pitch Servo Bracketry – S/N # E1-E571

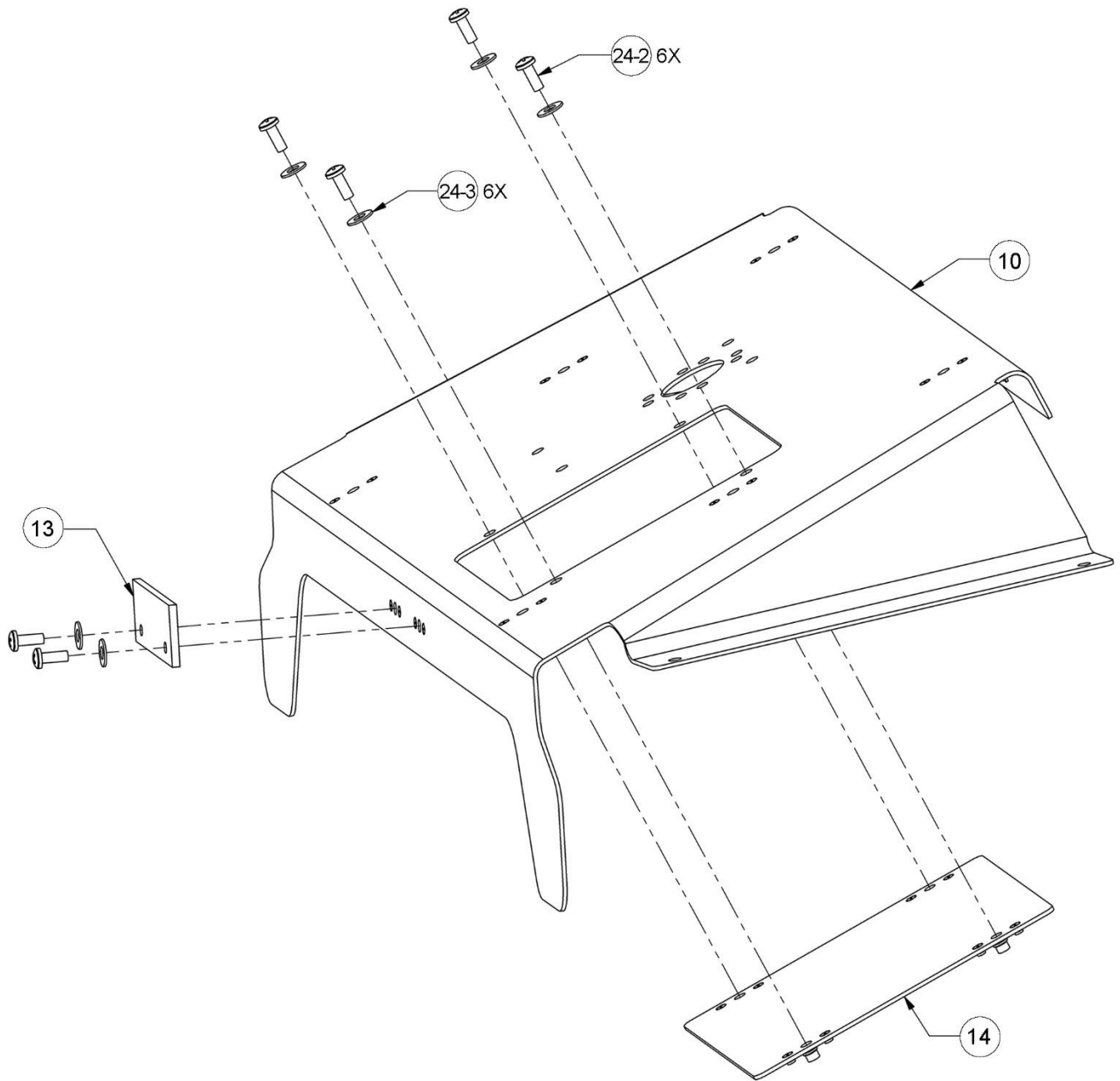

Figure 20: Attaching Cable Rub Strip and Optional Access Cover Plate

S/N # E1-E571 Only

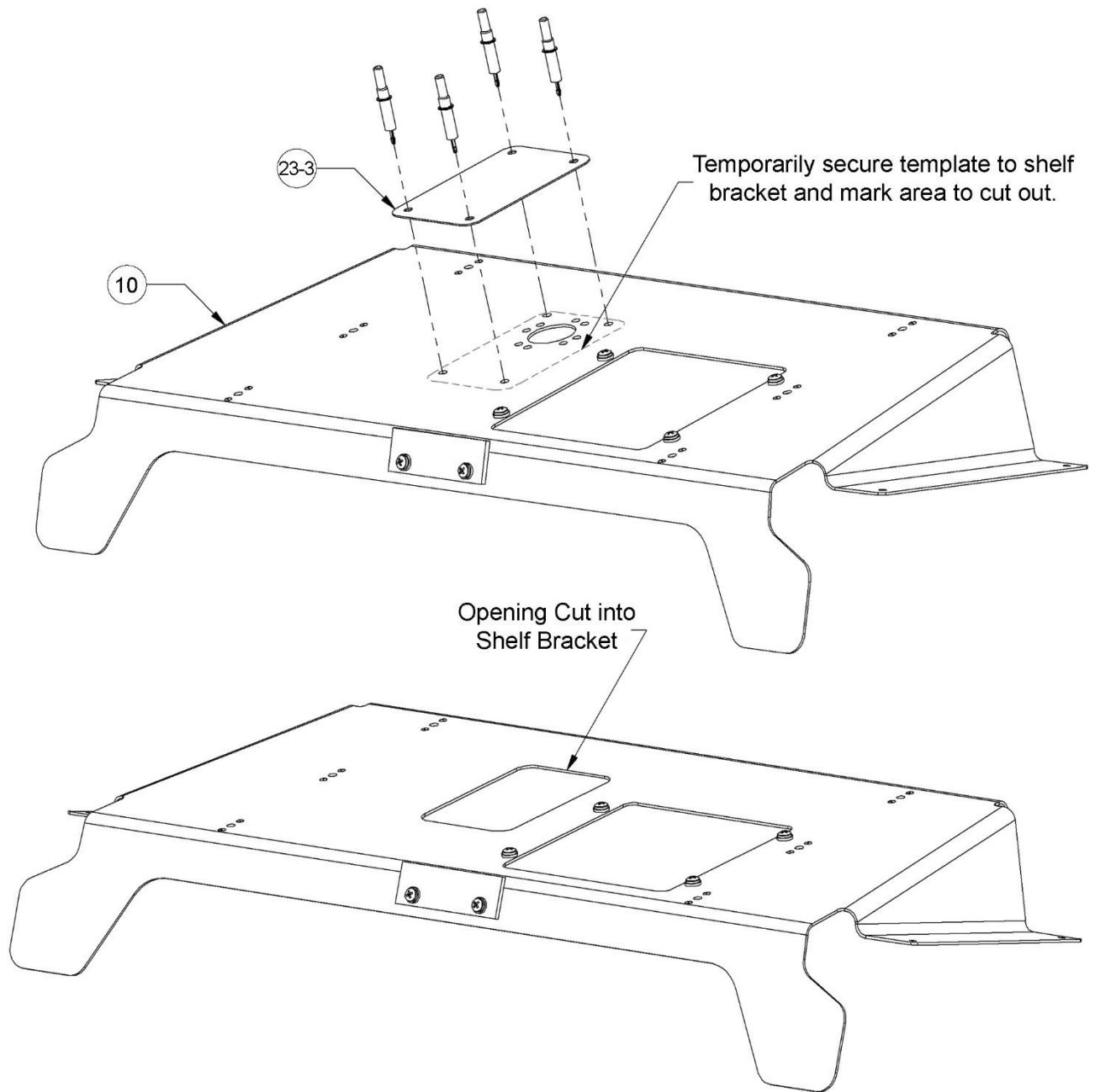

Figure 21: Cutting-out Opening in Shelf Bracket – S/N # E1-E571

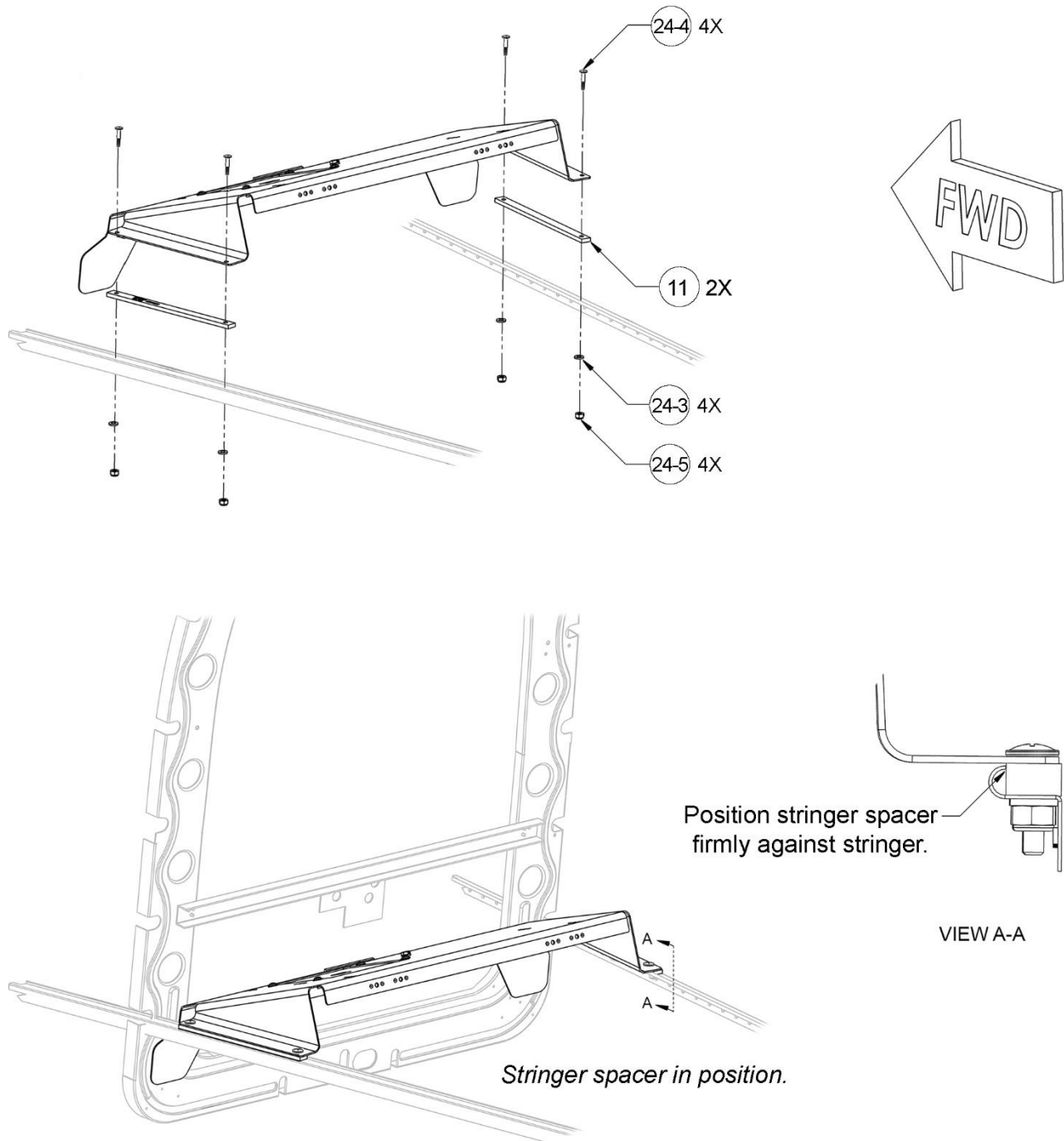
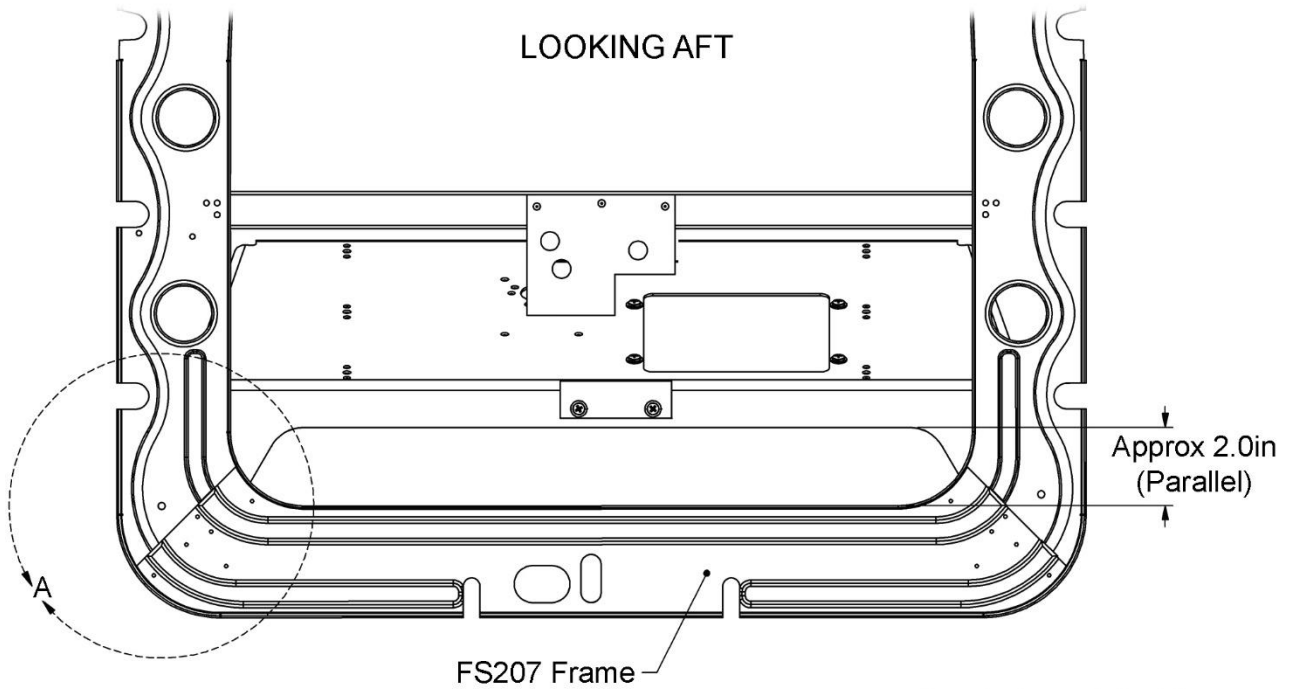
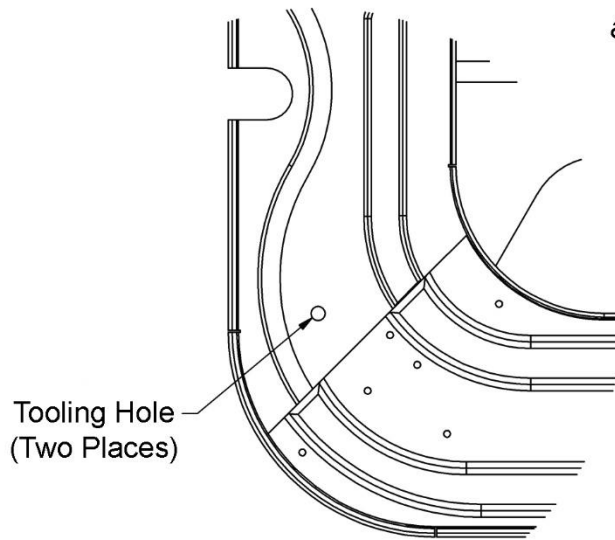

Figure 22: Positioning and Installing Shelf Bracket and Stringer Spacers



Bracket must first be square to the fuselage, and then aligned with the FS207 frame!



DETAIL A
SCALE 1 : 2

Figure 23: Aligning Shelf Bracket

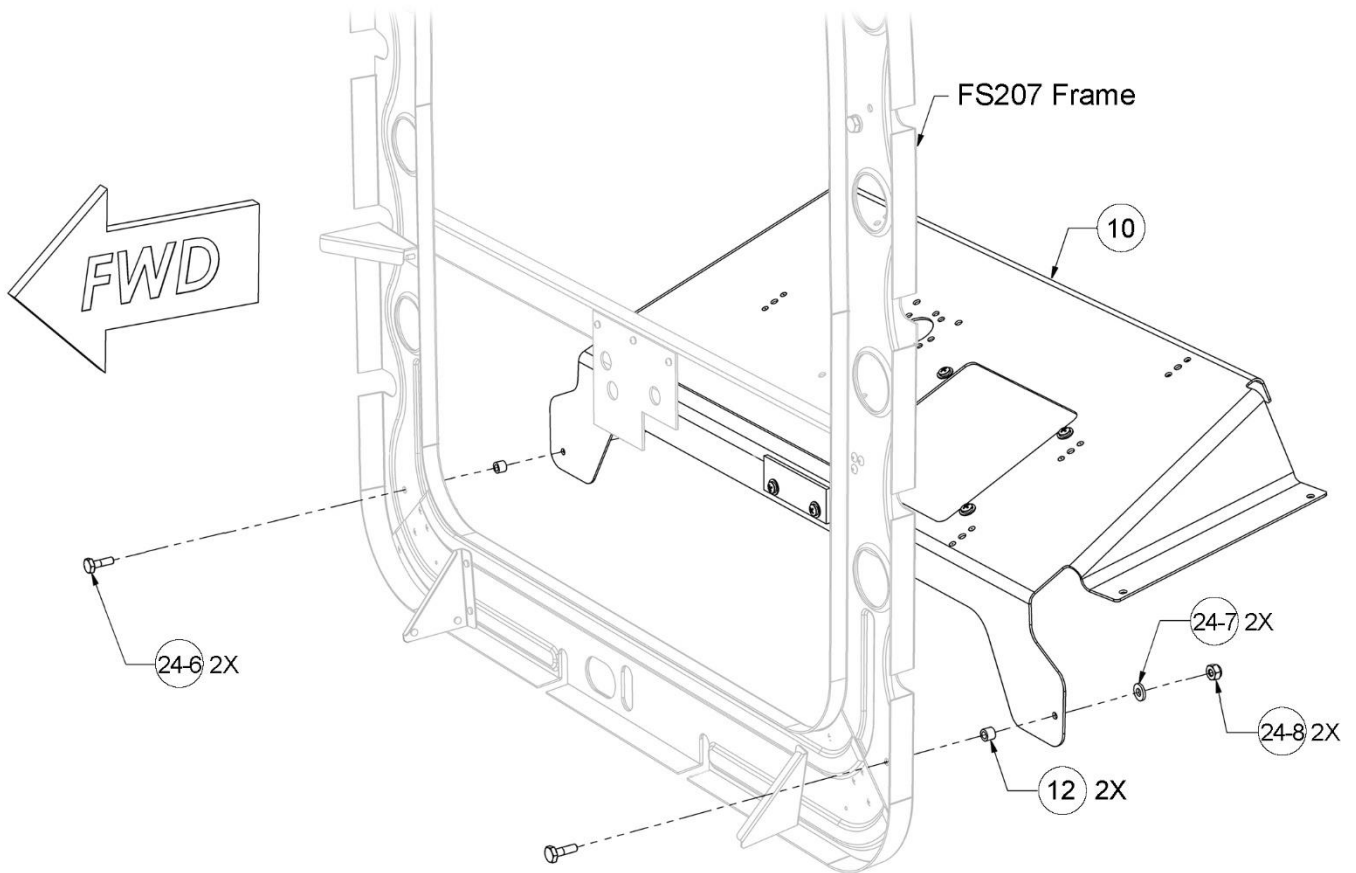

Figure 24: Positioning and Installing Shelf Bracket

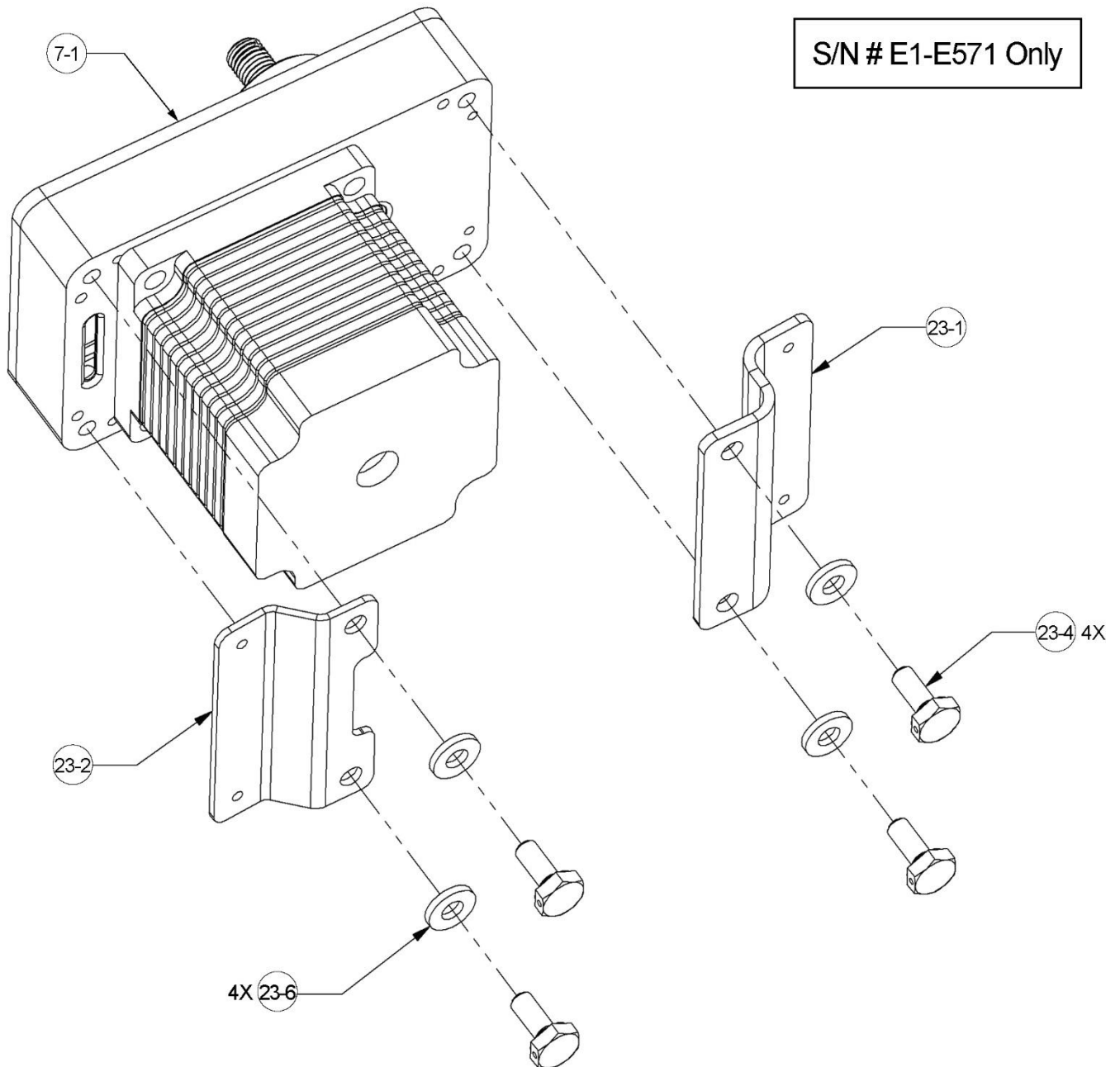

Figure 25: Attaching Adapter Brackets to Pitch Servo – S/N # E1-E571

S/N # E1-E571 Only

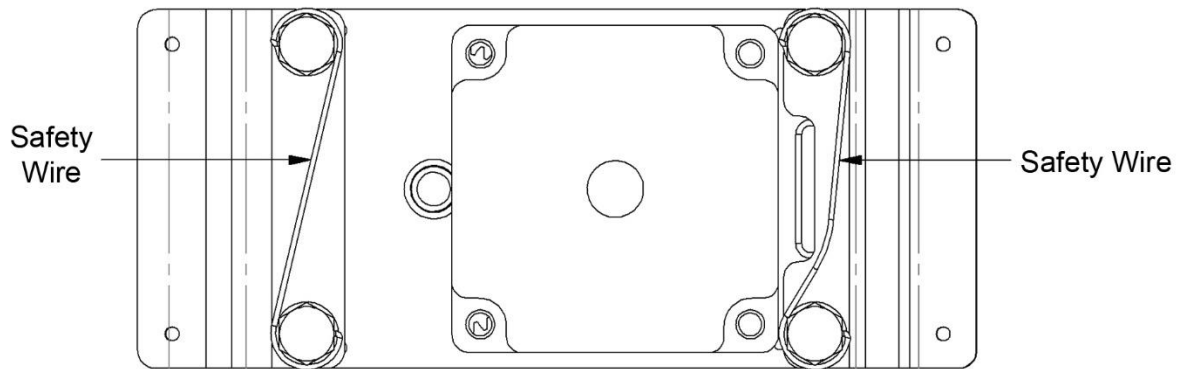

Figure 26: Pitch Servo Safety Wiring Example – S/N # E1-E571

S/N # E1-E571 Only

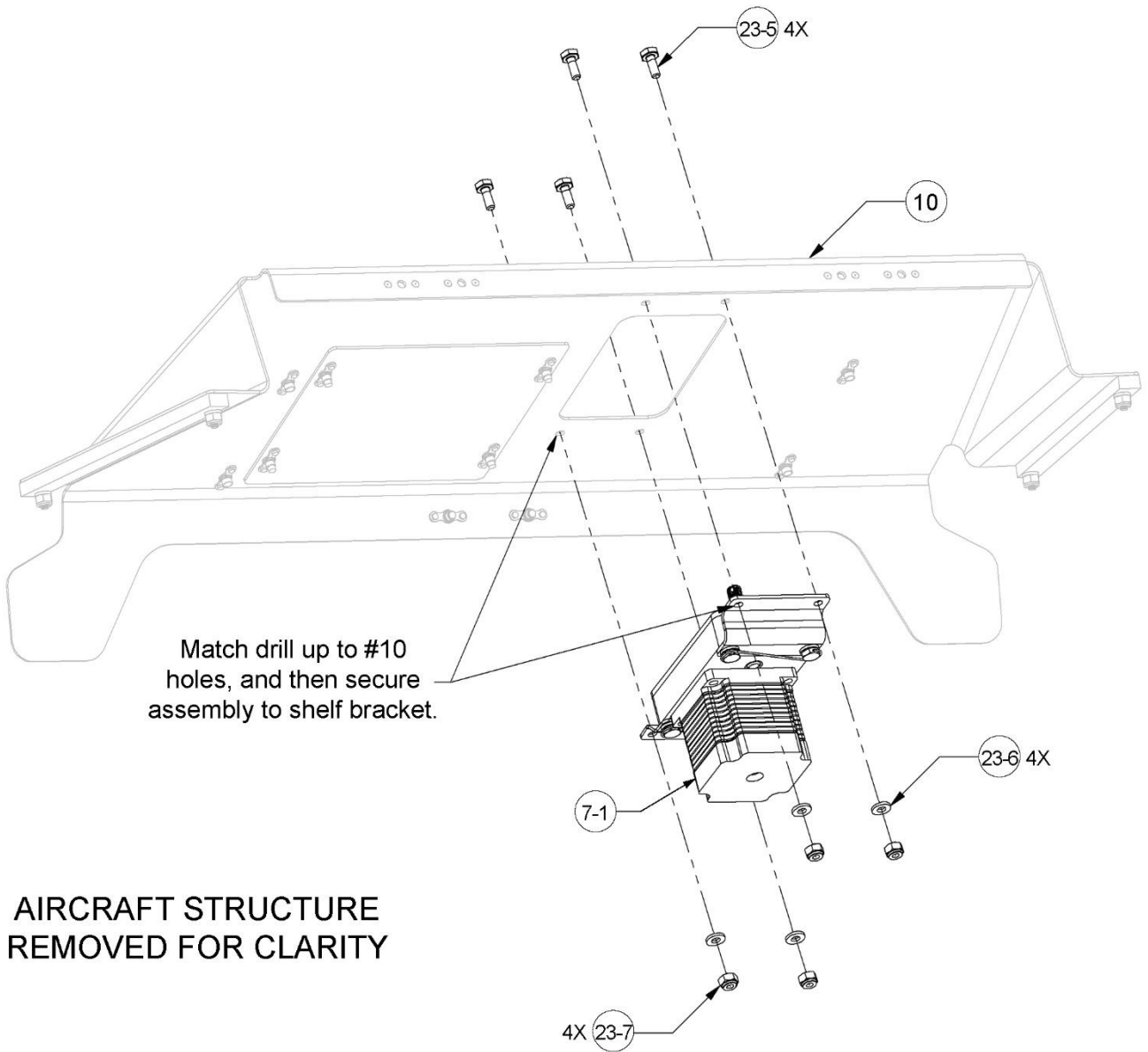

Figure 27: Attaching Adapter Brackets to Shelf Bracket – S/N # E1-E571

S/N # E572 + Only

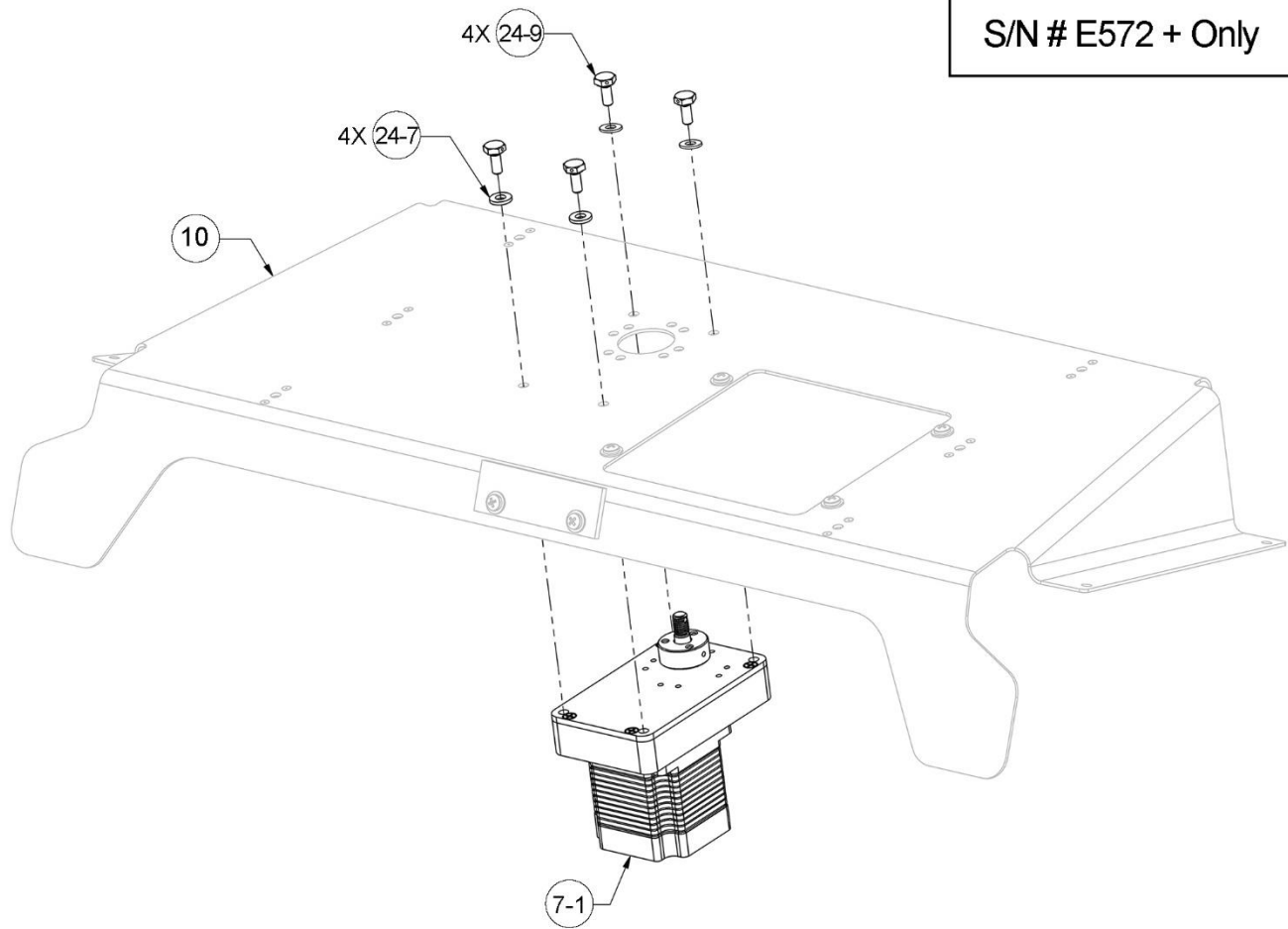

Figure 28: Attaching Pitch Servo to Shelf Bracket

S/N # E572 + Only

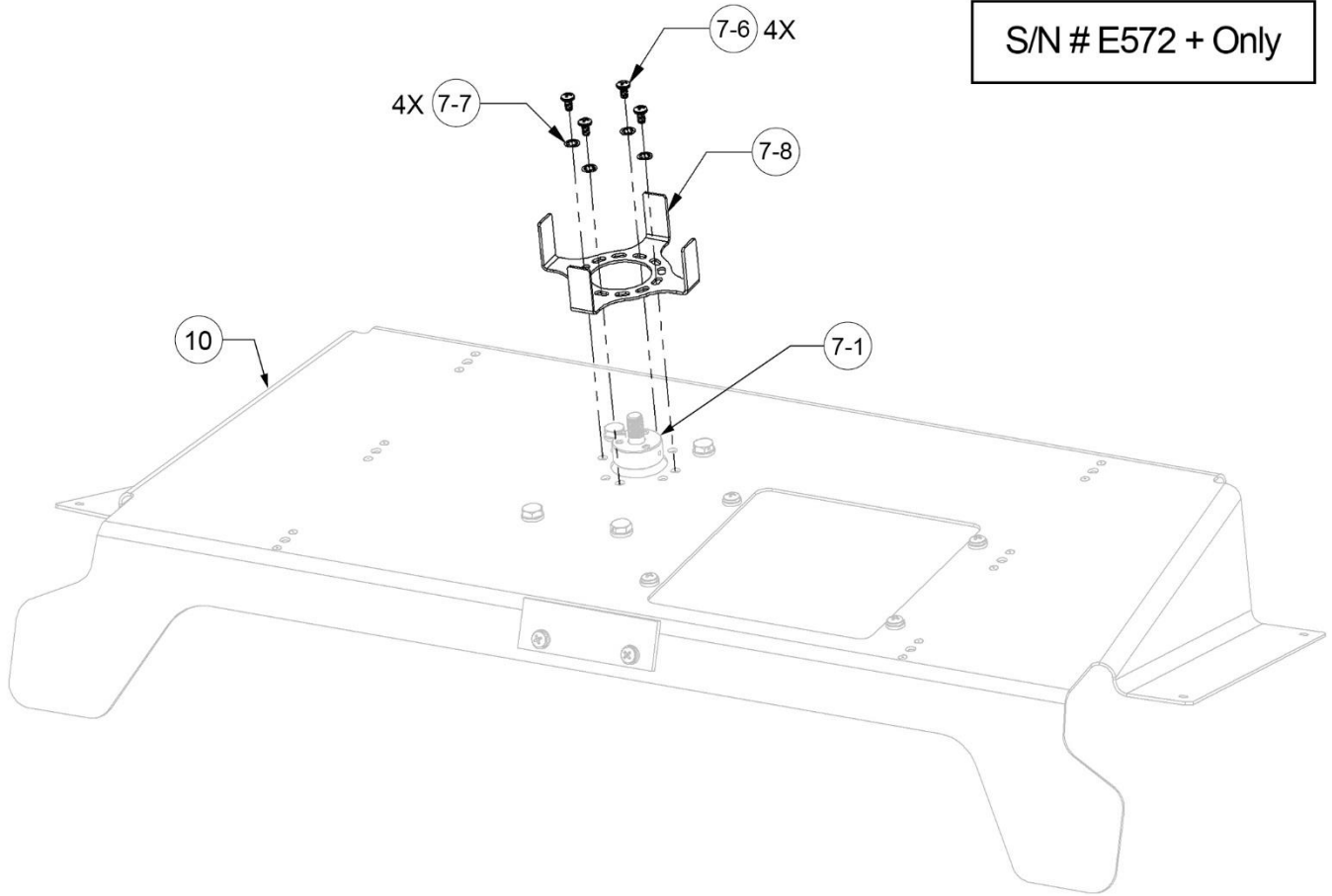

Figure 29: Attaching Cable Guard to Pitch Servo

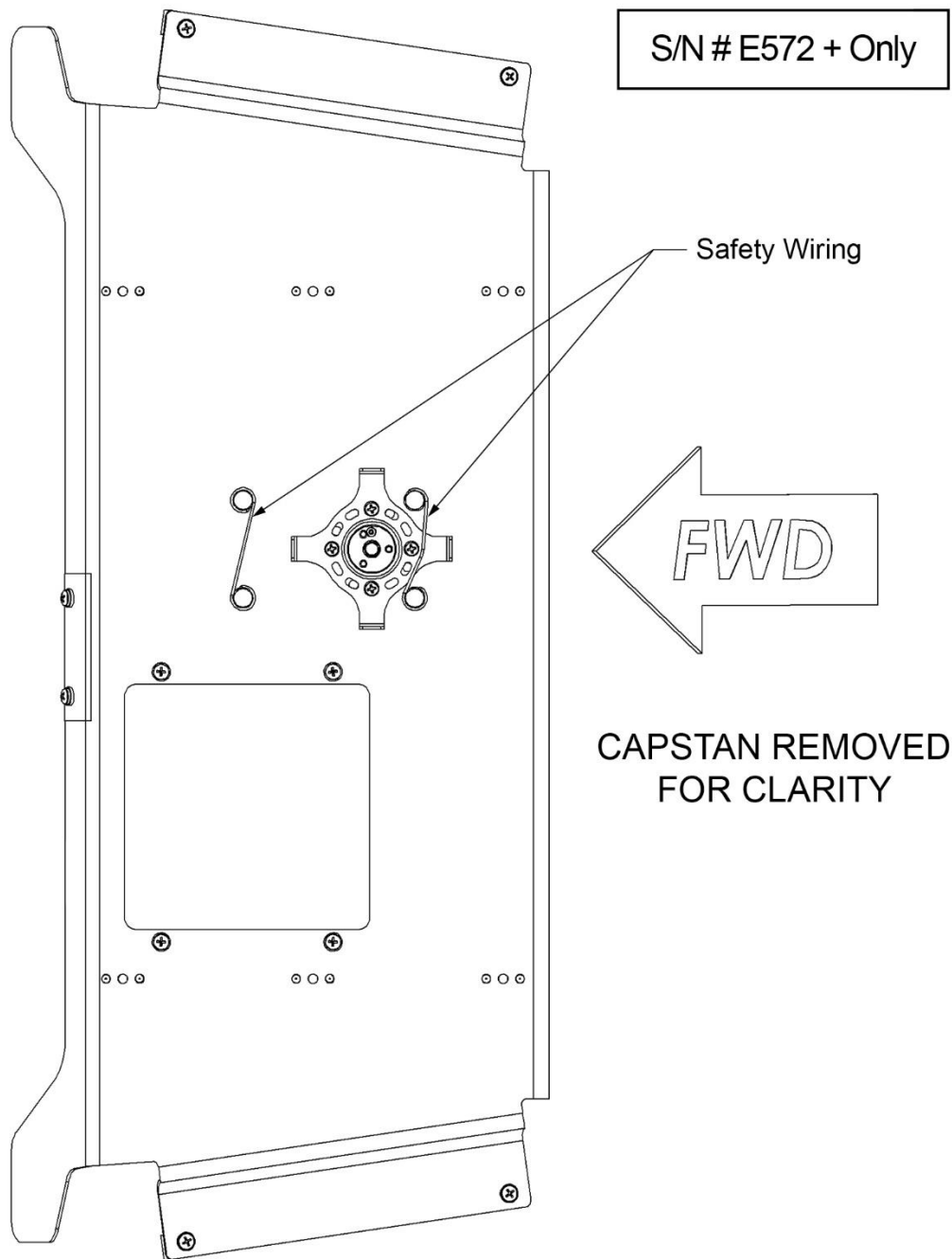

Figure 30: Pitch Servo Safety Wiring Example

S/N # E1-E571 Only

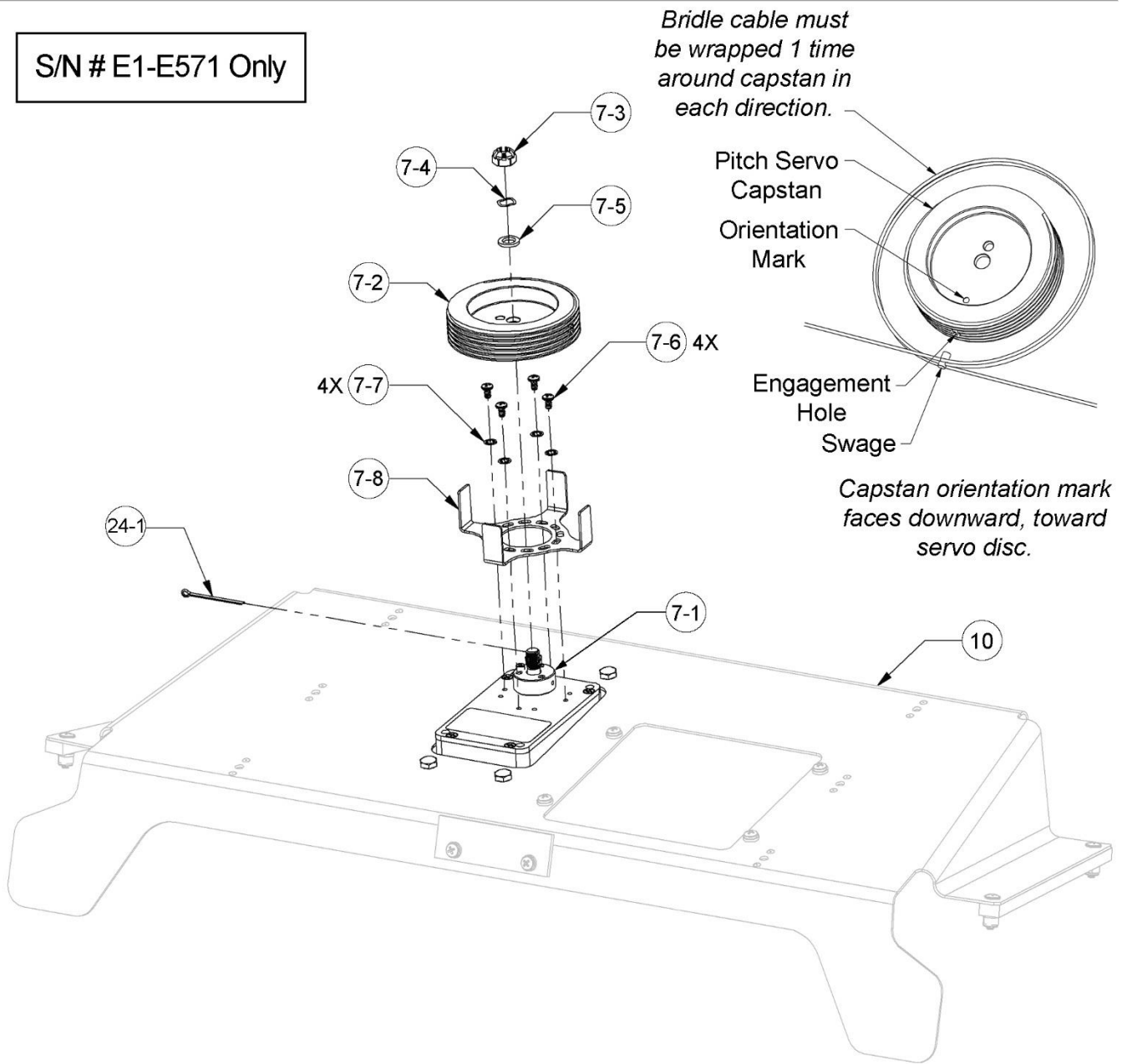

Figure 31: Installing Pitch Servo Capstan and Bridle Cable – S/N # E1-E571

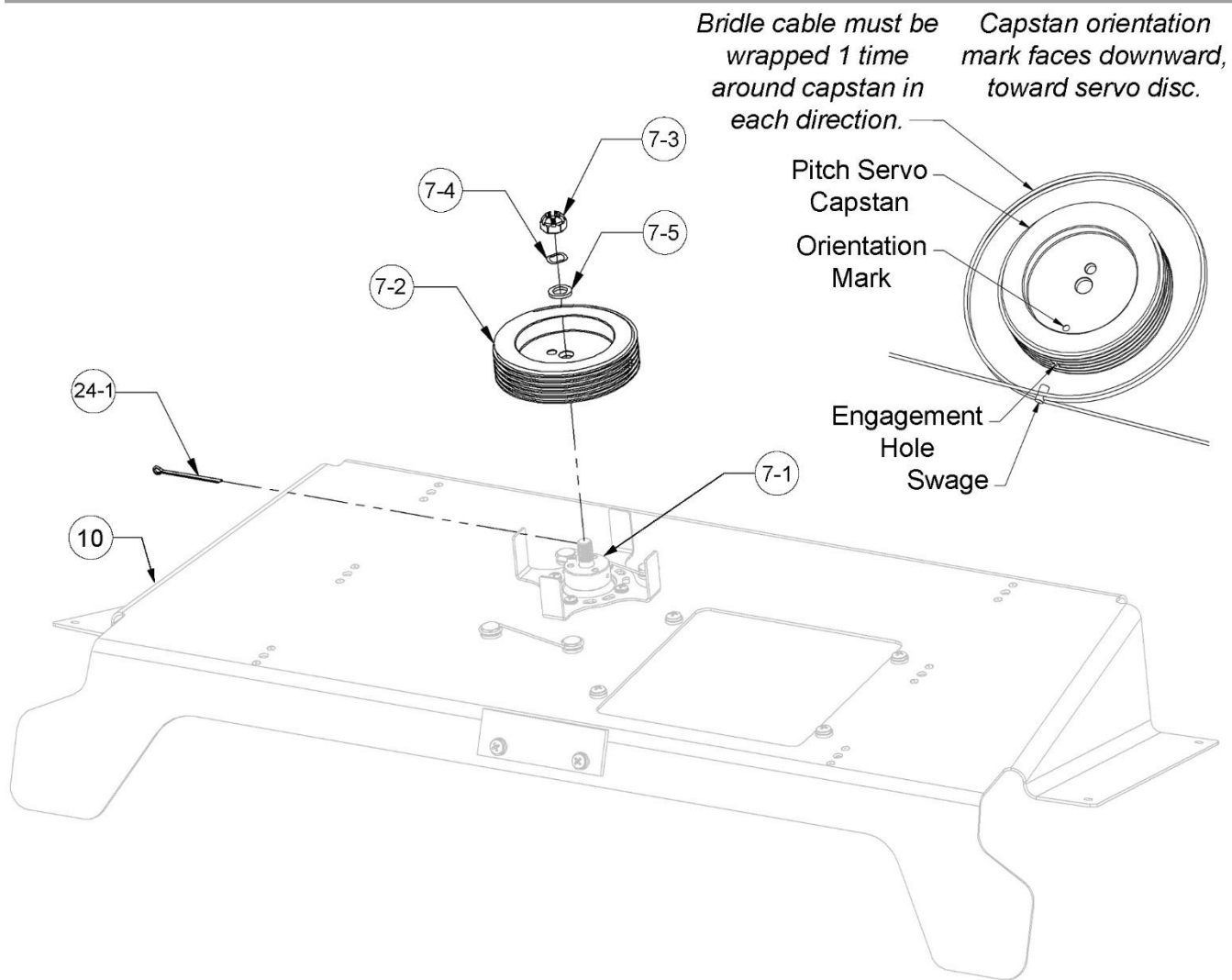

Figure 32: Installing Pitch Servo Capstan and Bridle Cable

LOOKING DOWN PERPENDICULAR TO CAPSTAN

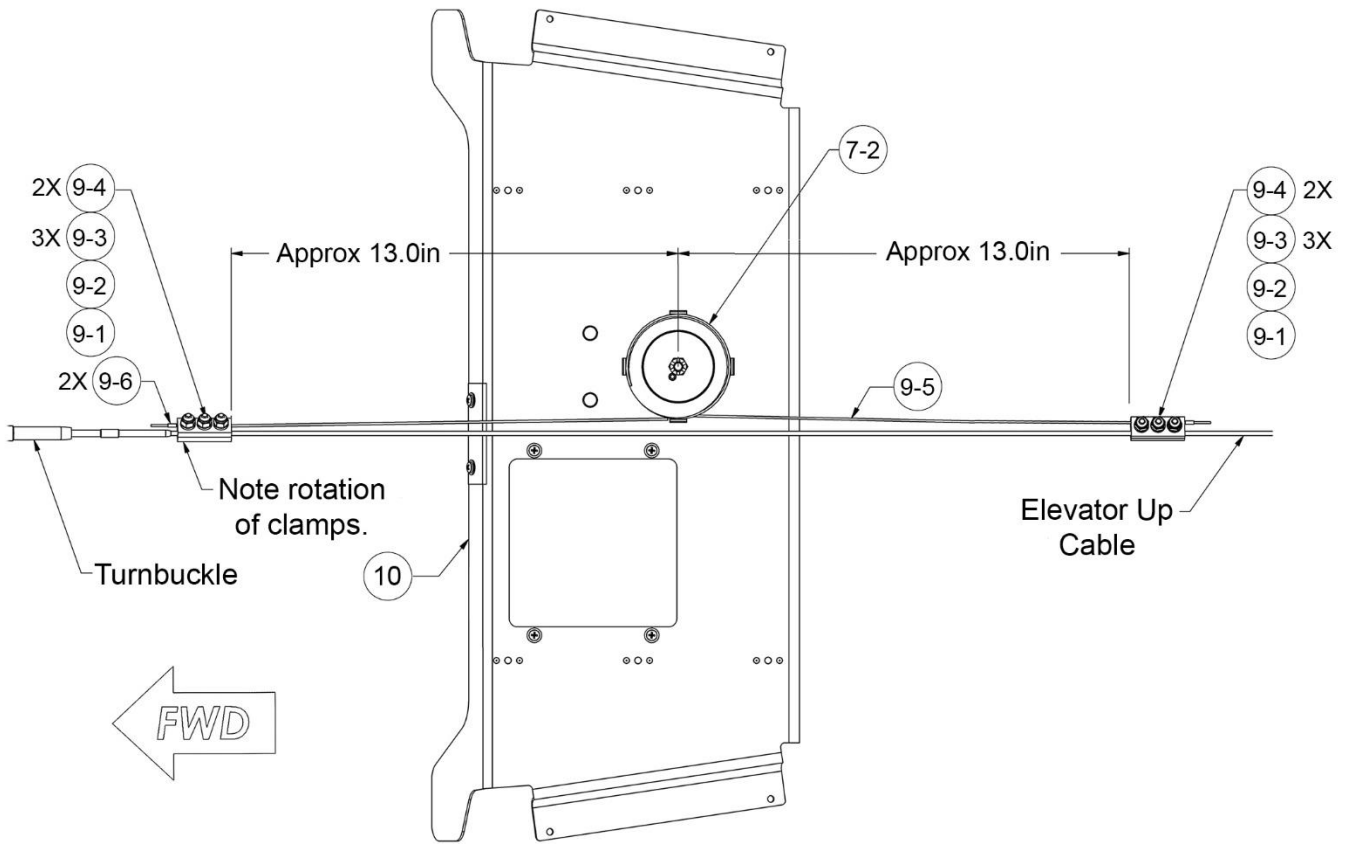

Figure 33: Connecting Pitch Servo Bridle Cable to Elevator Up Cable

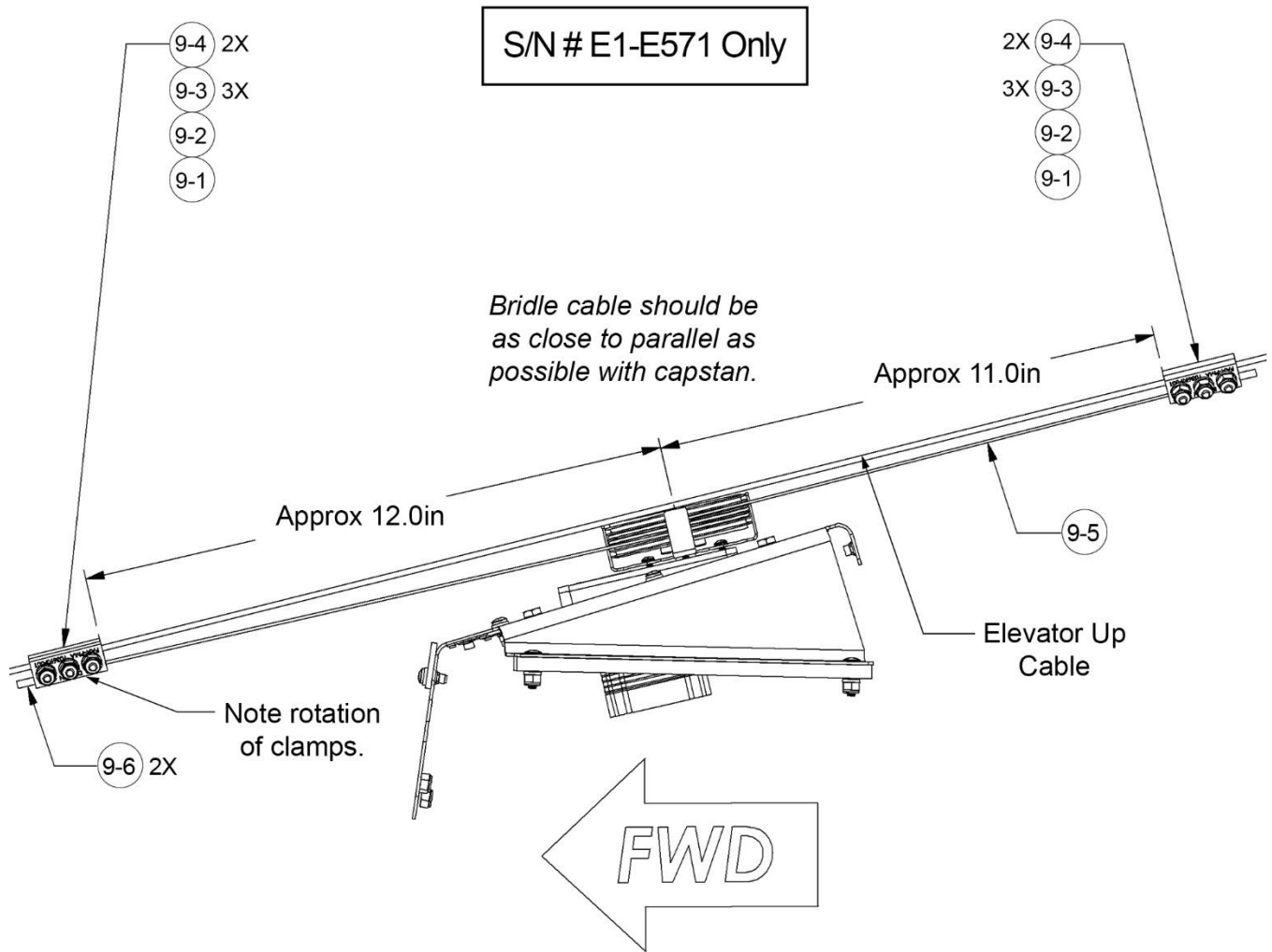

Figure 34: Connecting Pitch Servo Bridle Cable to Elevator Up Cable – S/N # E1-E571

12.3 Yaw Servo Figures

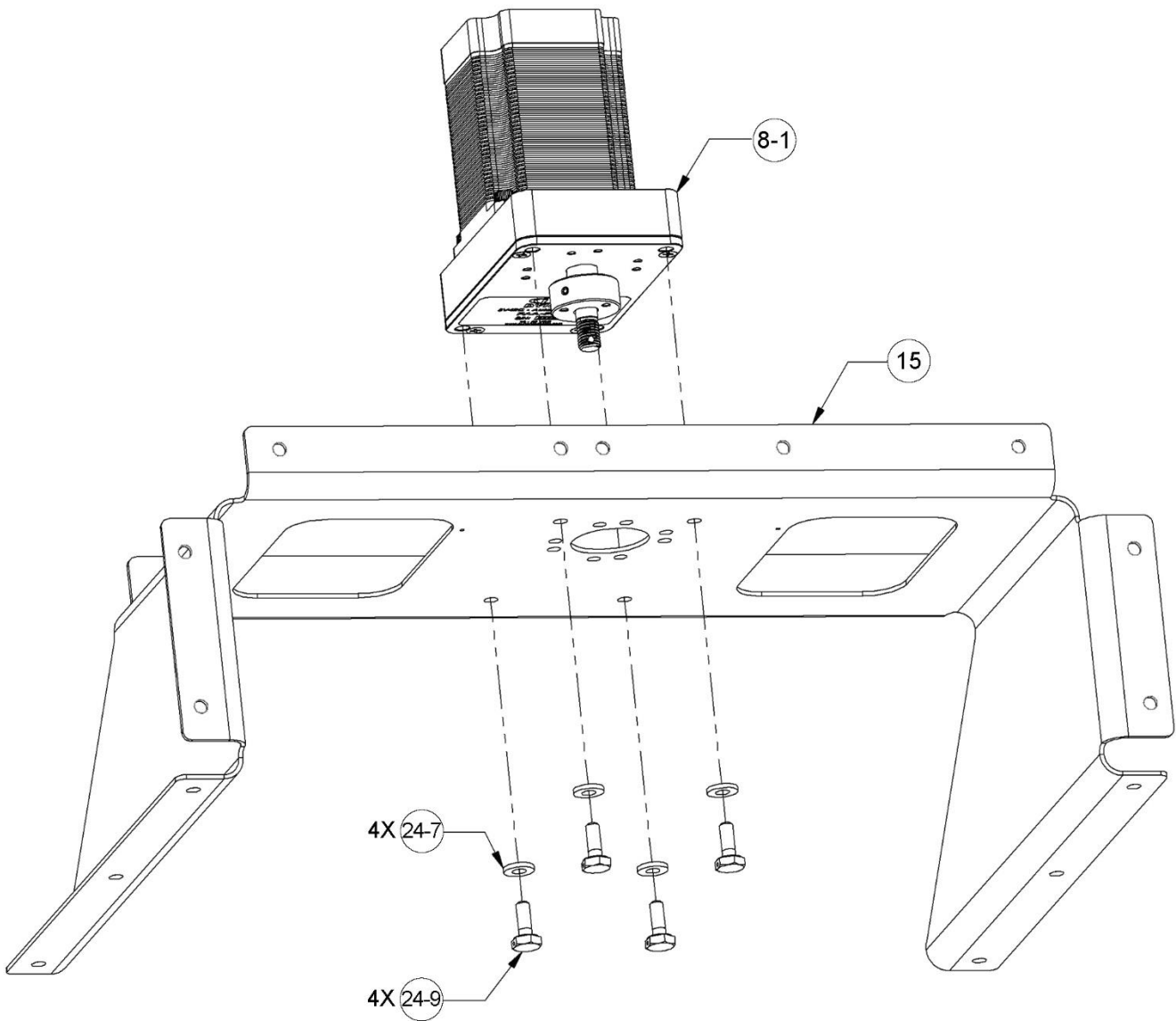

Figure 35: Attaching Yaw Servo to Bridge Bracket

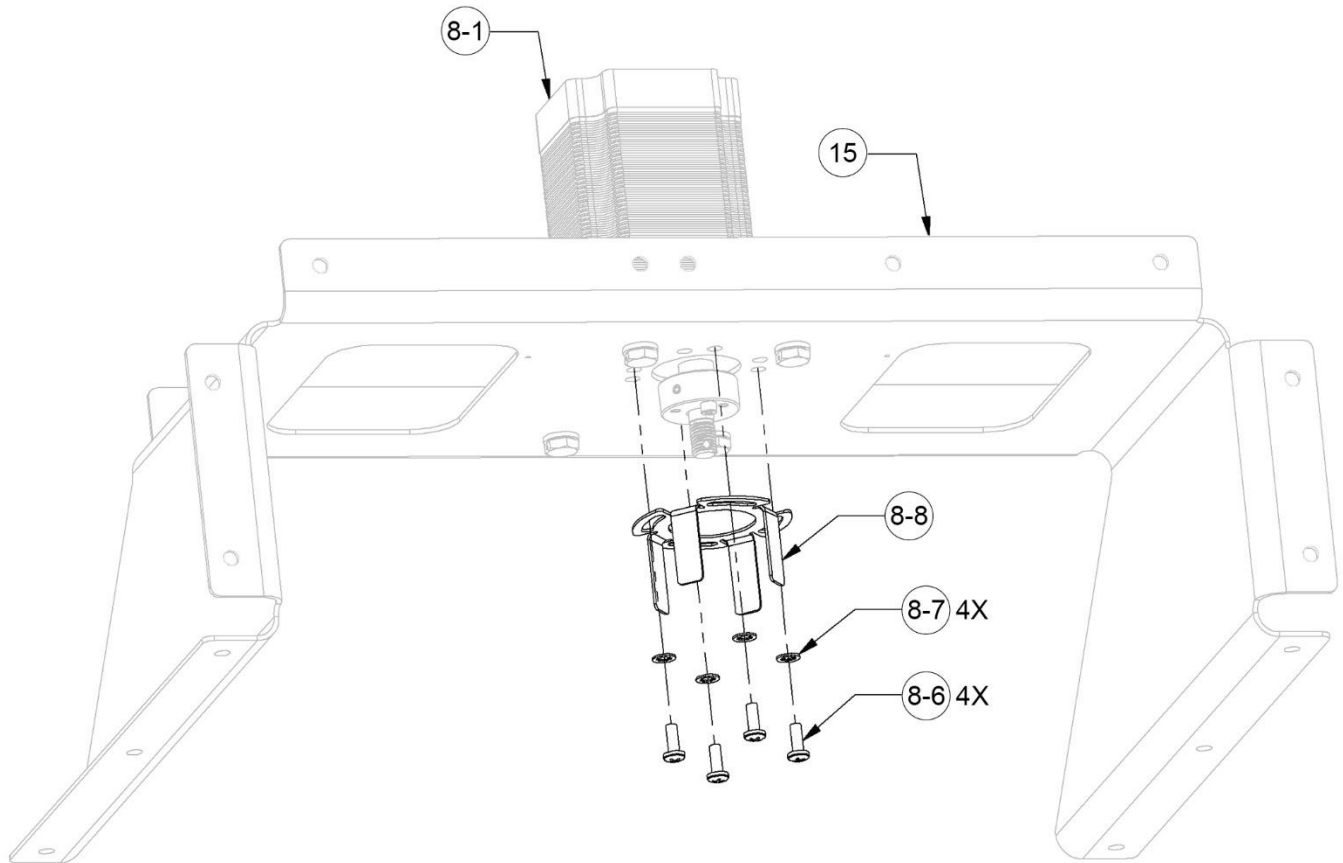

Figure 36: Attaching Cable Guard to Yaw Servo

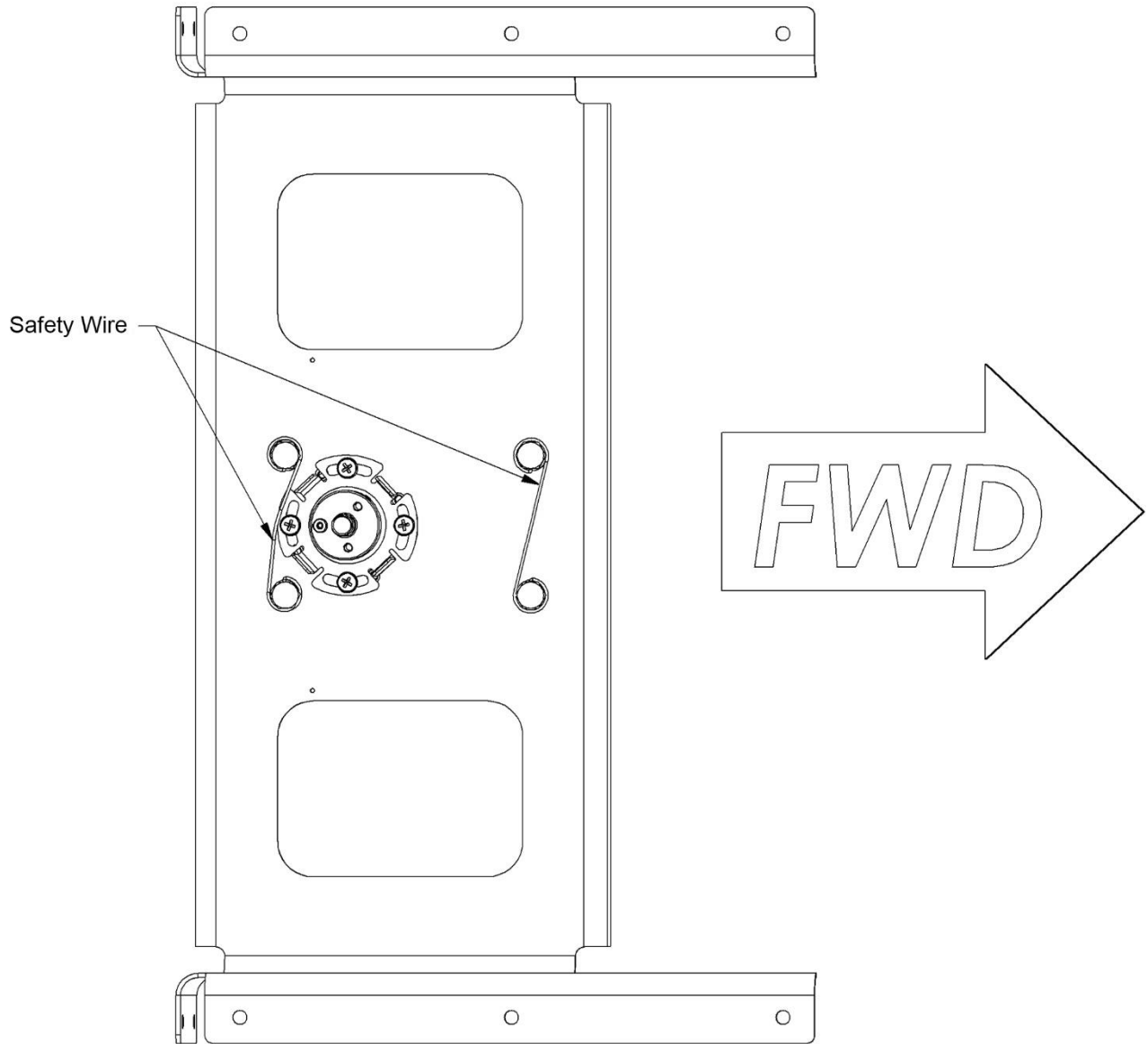

Figure 37: Yaw Servo Safety Wiring Example

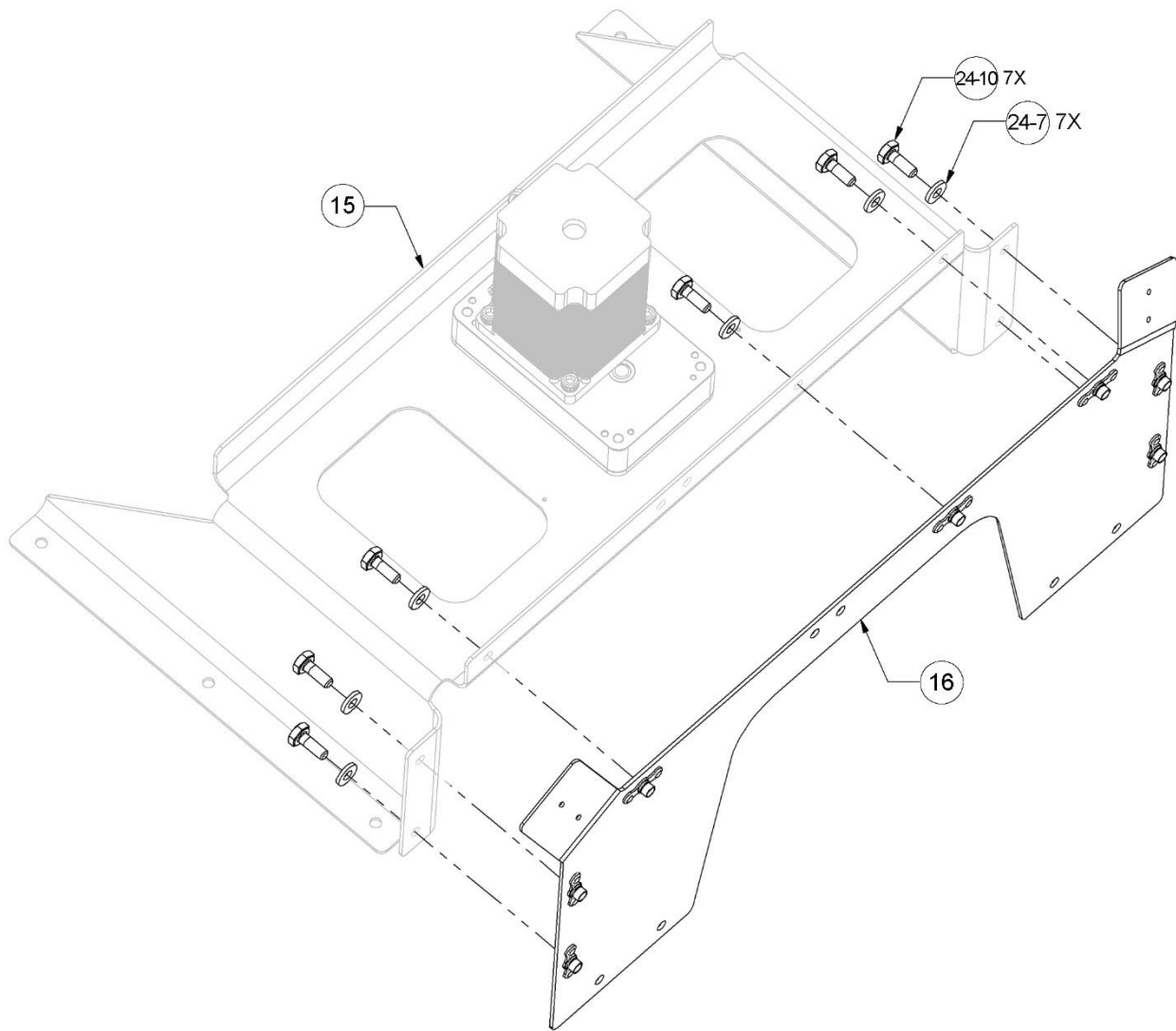

Figure 38: Attaching Boxing Plate to Bridge Bracket

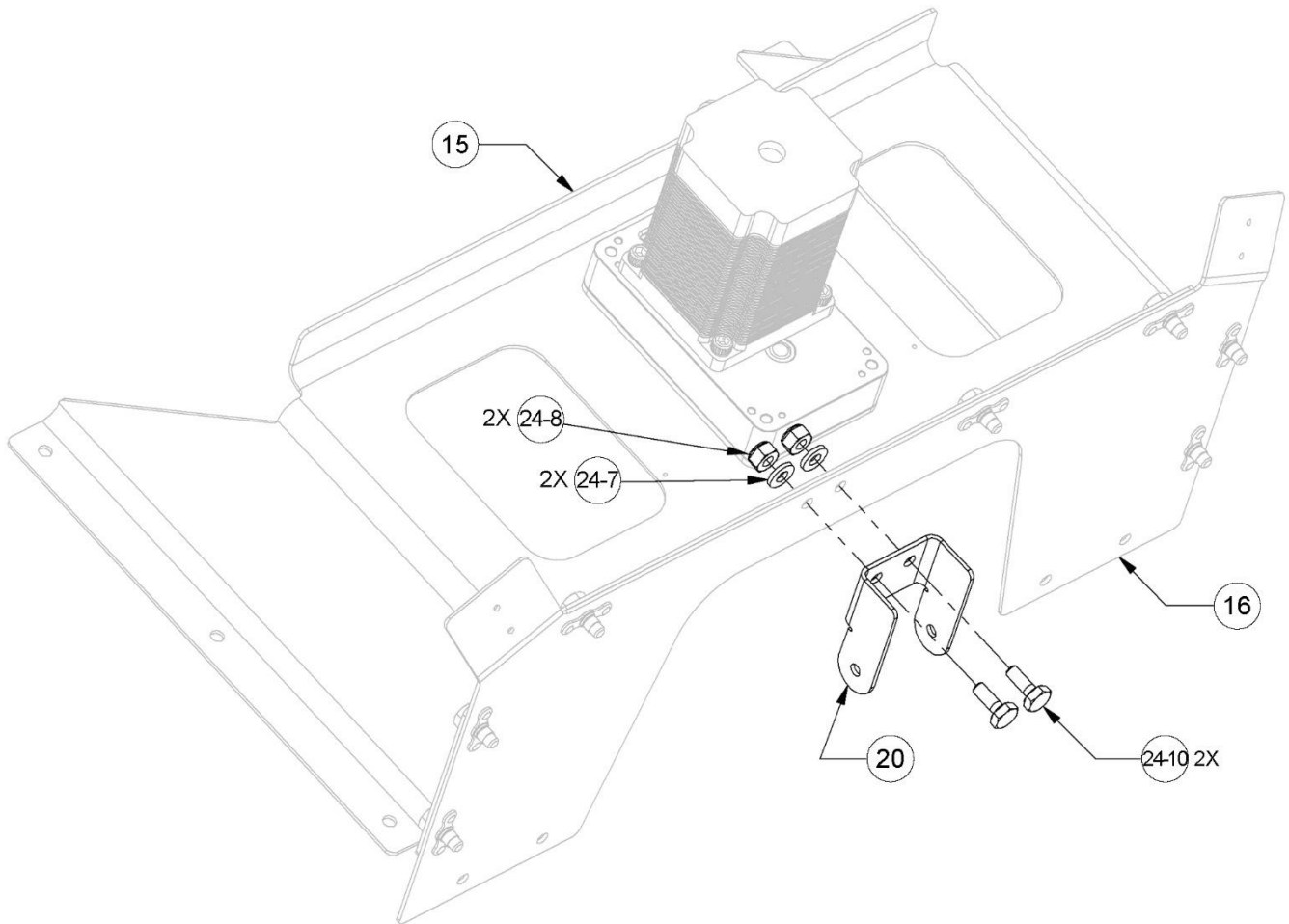

Figure 39: Attaching Roller Bracket to Bracket Assembly

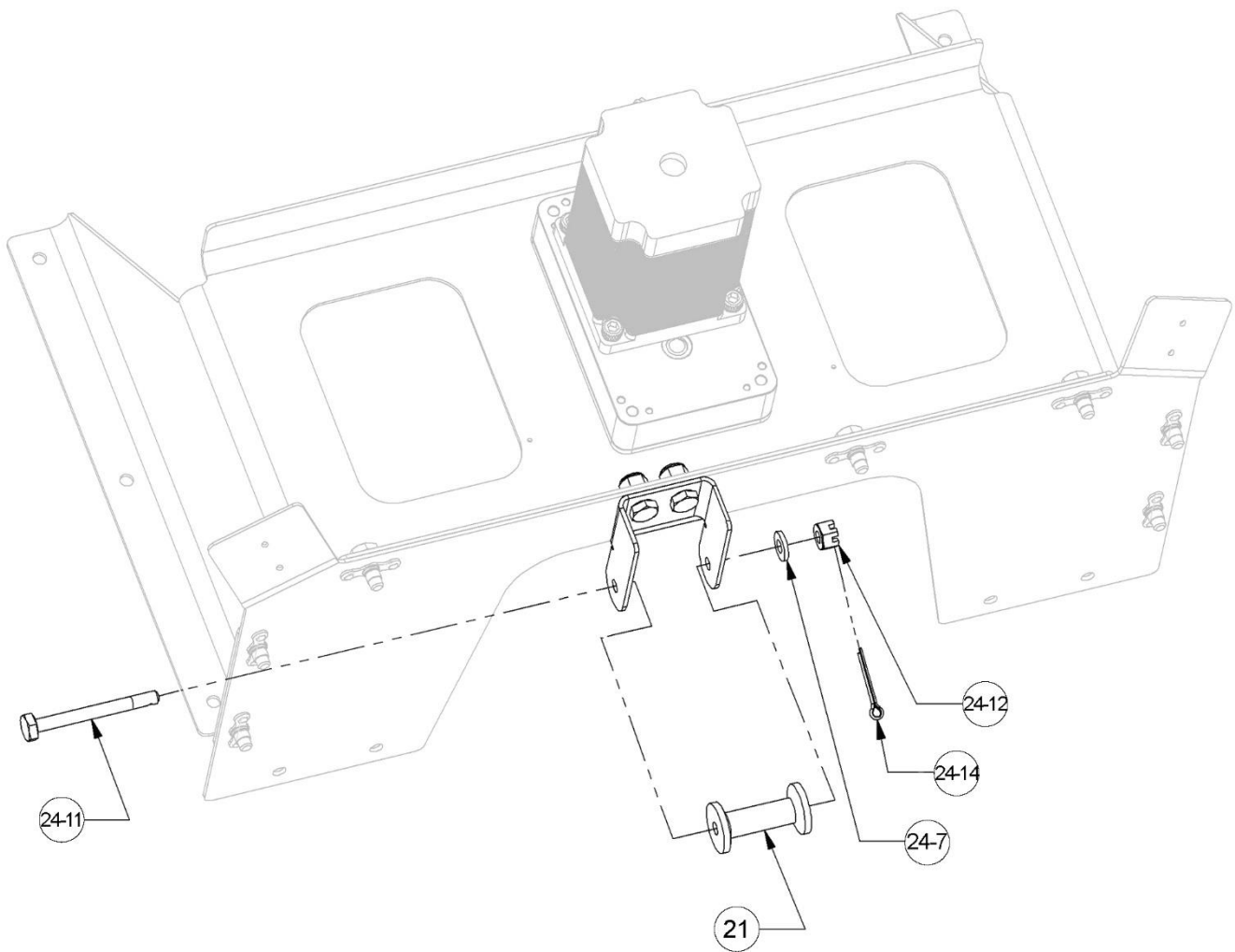
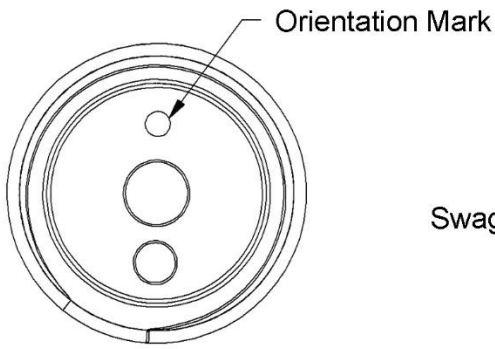

Figure 40: Installing Roller

CAPSTAN ORIENTATION



Capstan orientation mark faces upward, toward servo disc.

BRIDLE CABLE WRAP

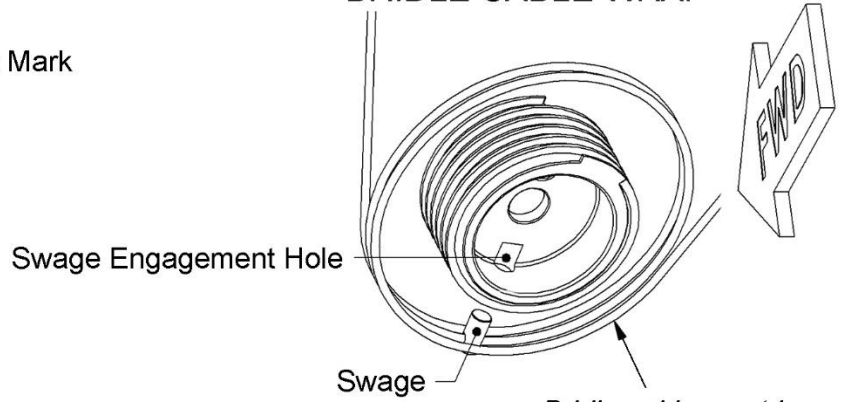

Bridle cable must be wrapped 1-1/4 times around capstan in each direction.

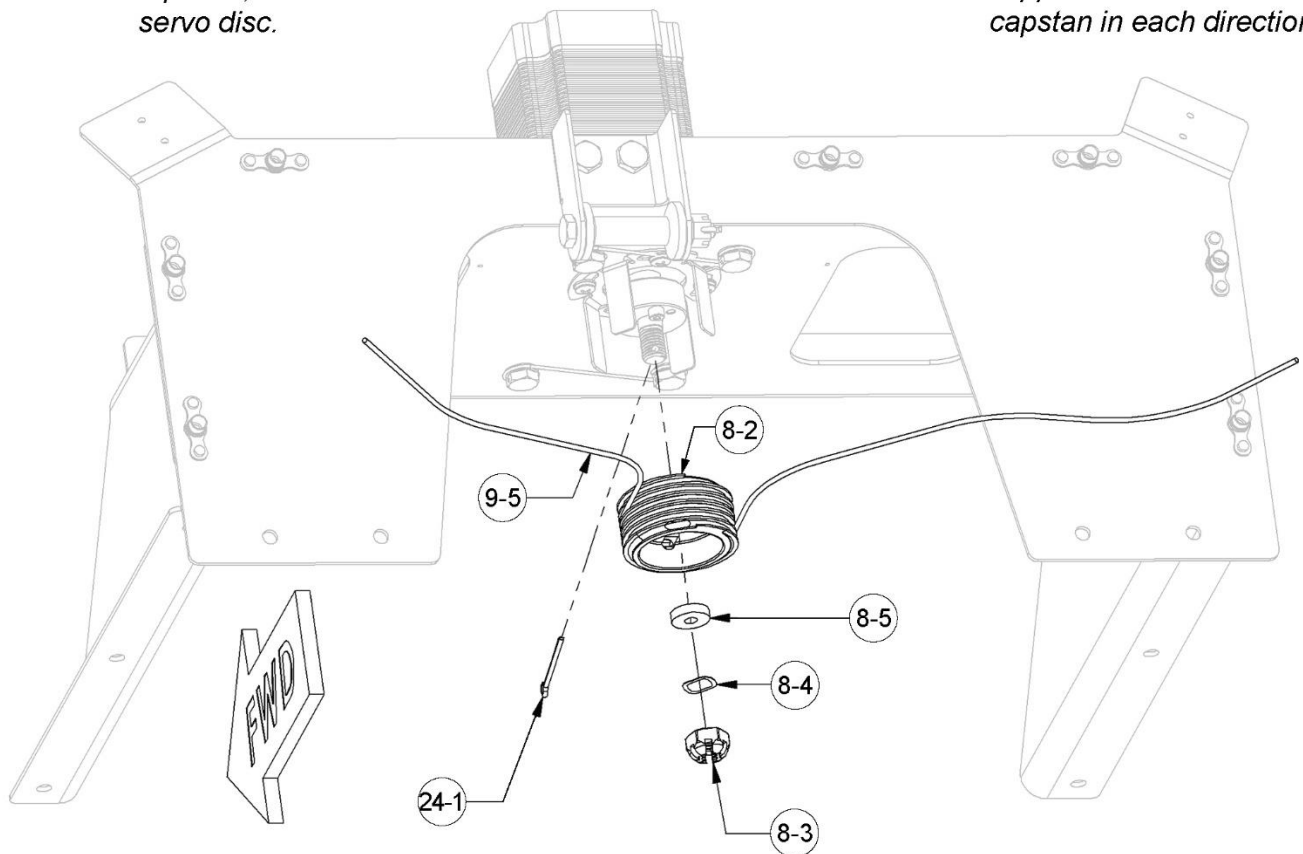

Figure 41: Installing Yaw Servo Capstan and Bridle Cable

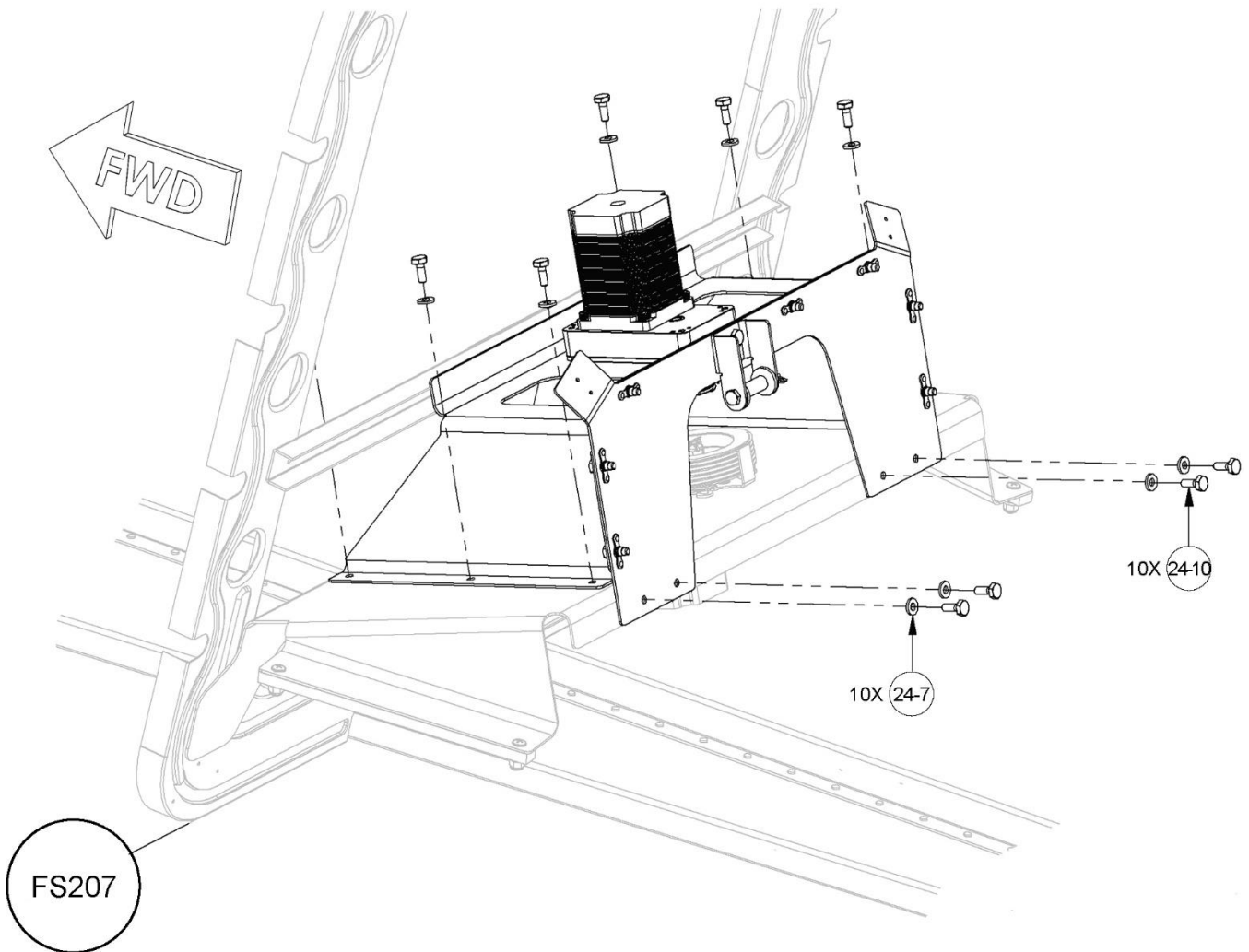

Figure 42: Installing Yaw Servo and Bracket Assembly

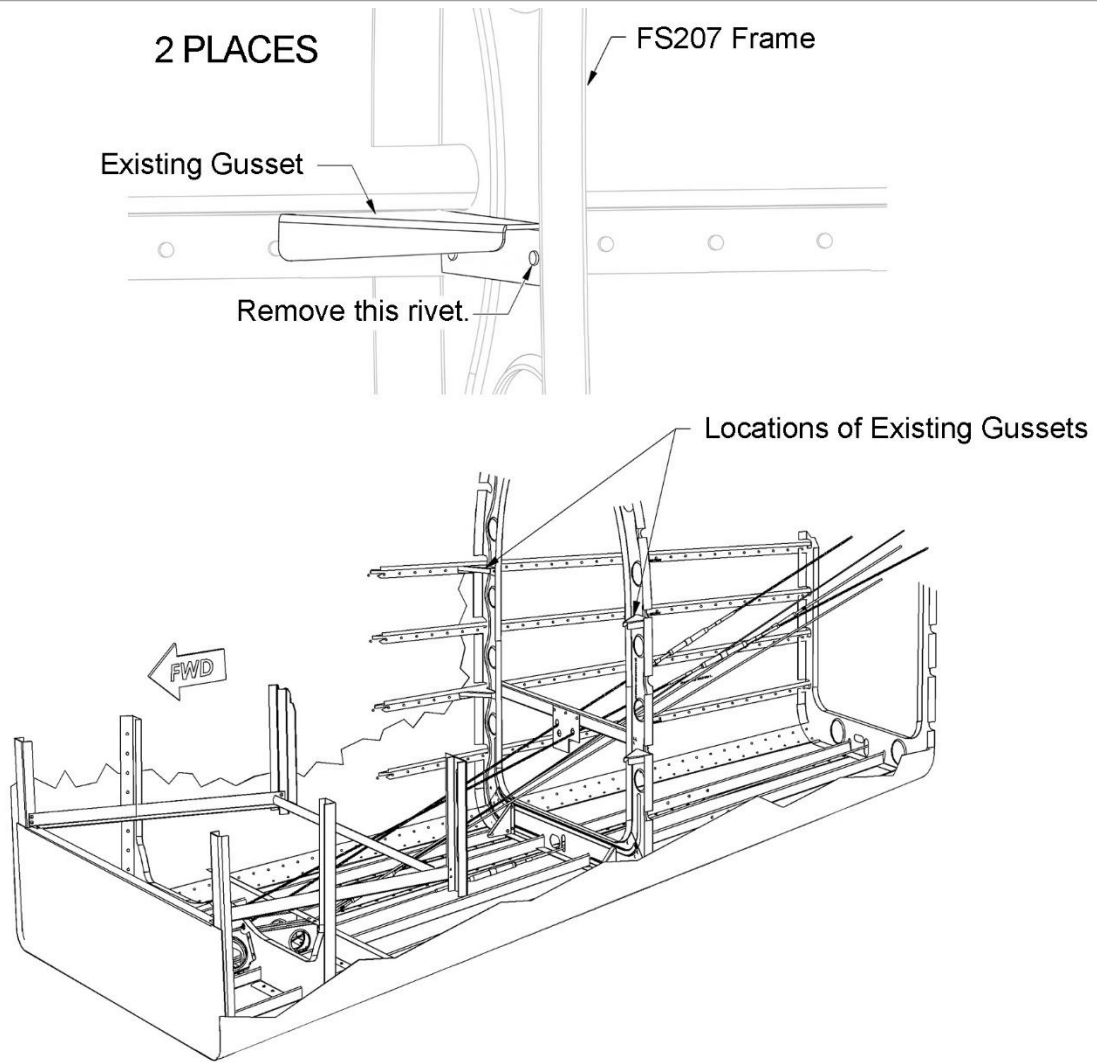

Figure 43: Removing Rivets on Existing Gussets

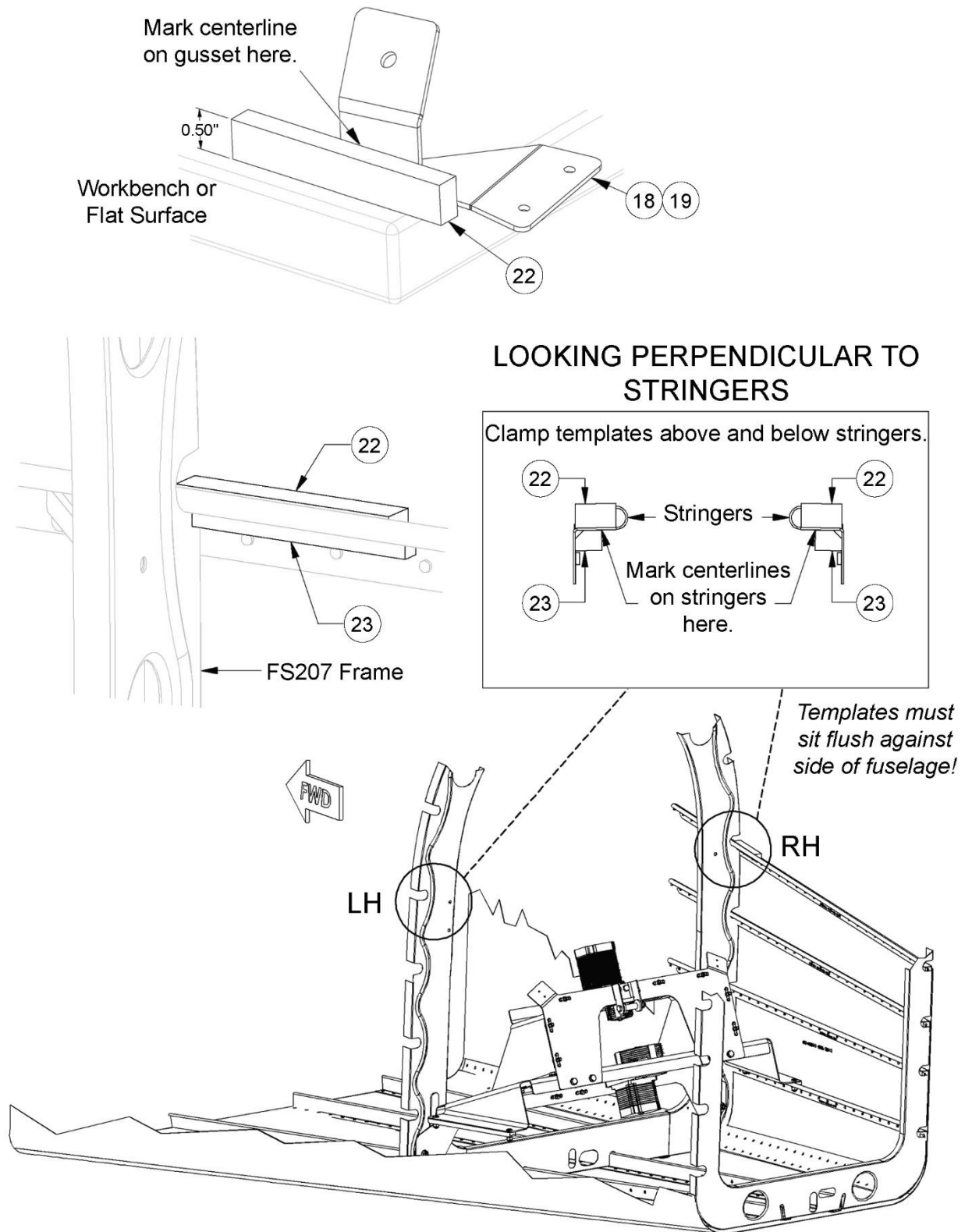

Figure 44: Marking Centerlines on Gussets and Stringers

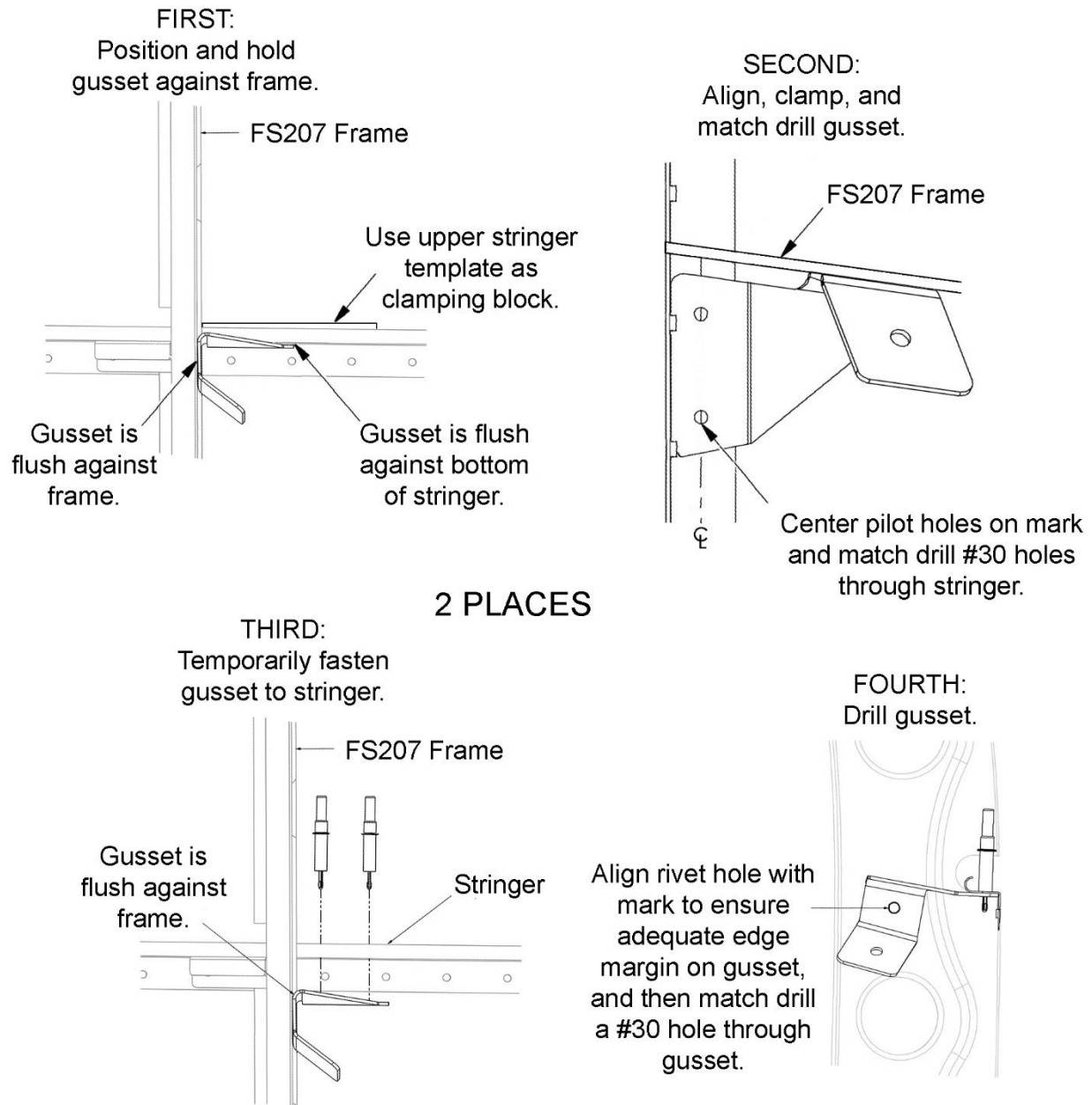

Figure 45: Temporarily Fastening Gussets to Stringers

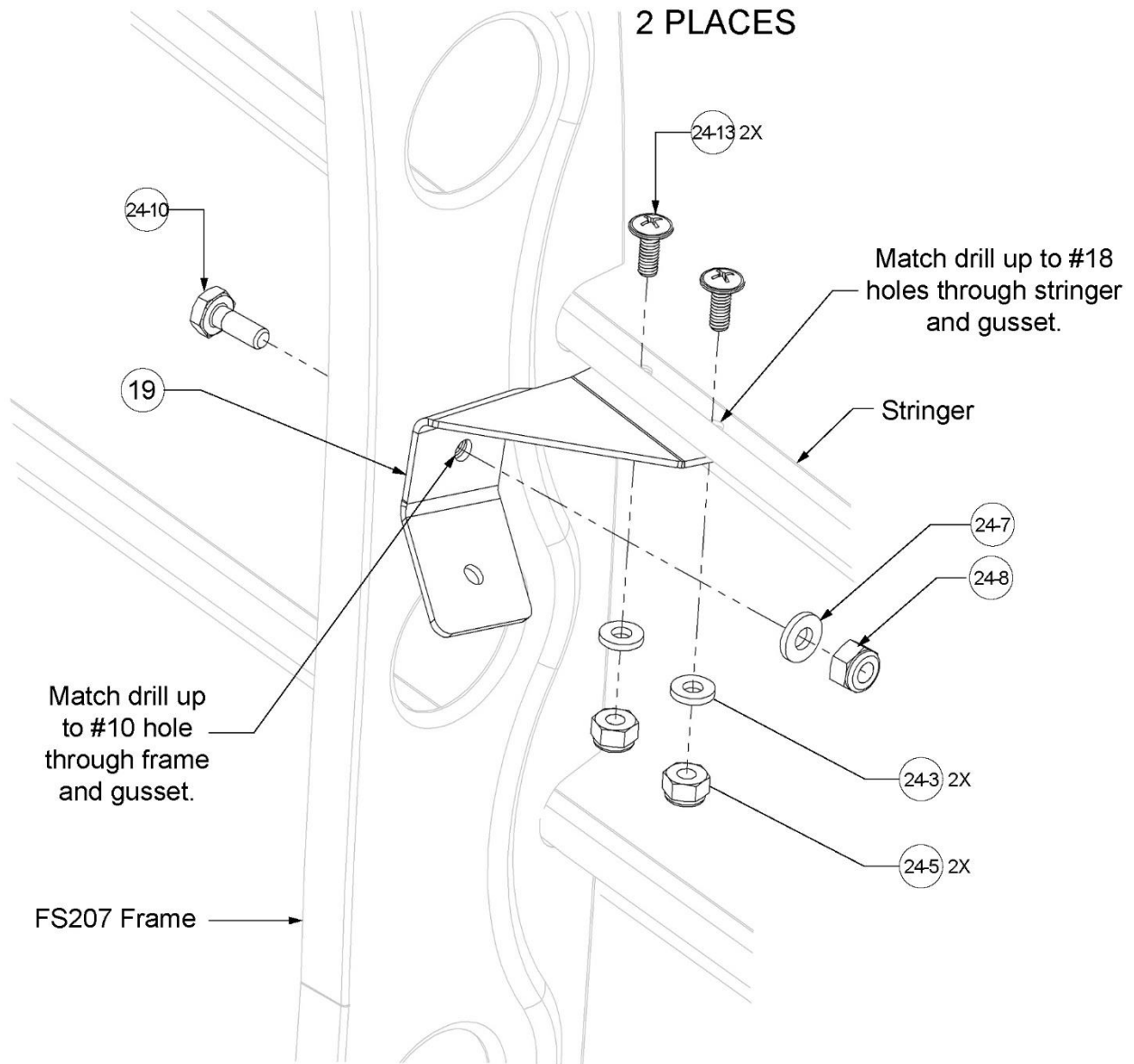

Figure 46: Attaching Gussets to Frame and Stringers (Right Side Shown)

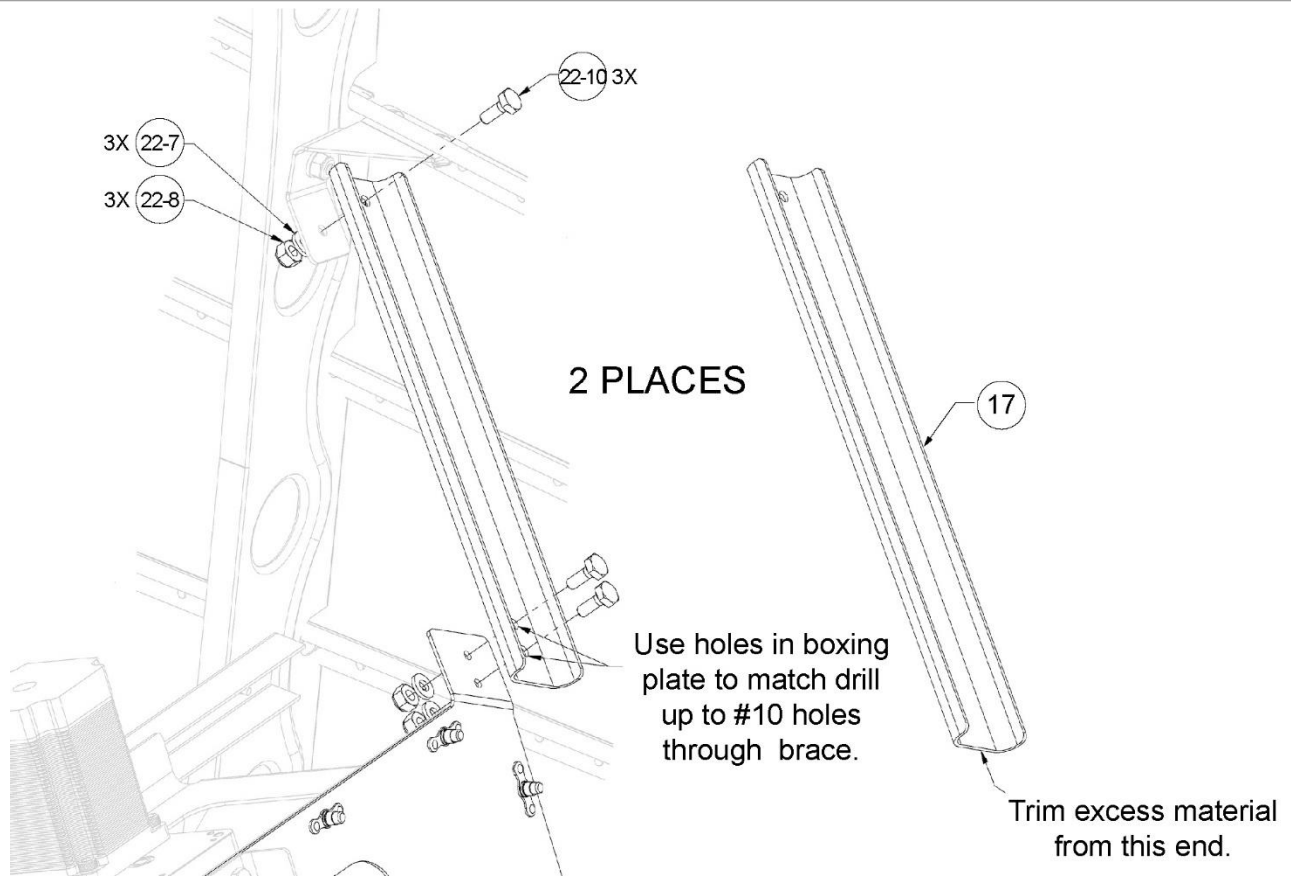

Figure 47: Attaching Bracket Assembly Braces (Right Side Shown)

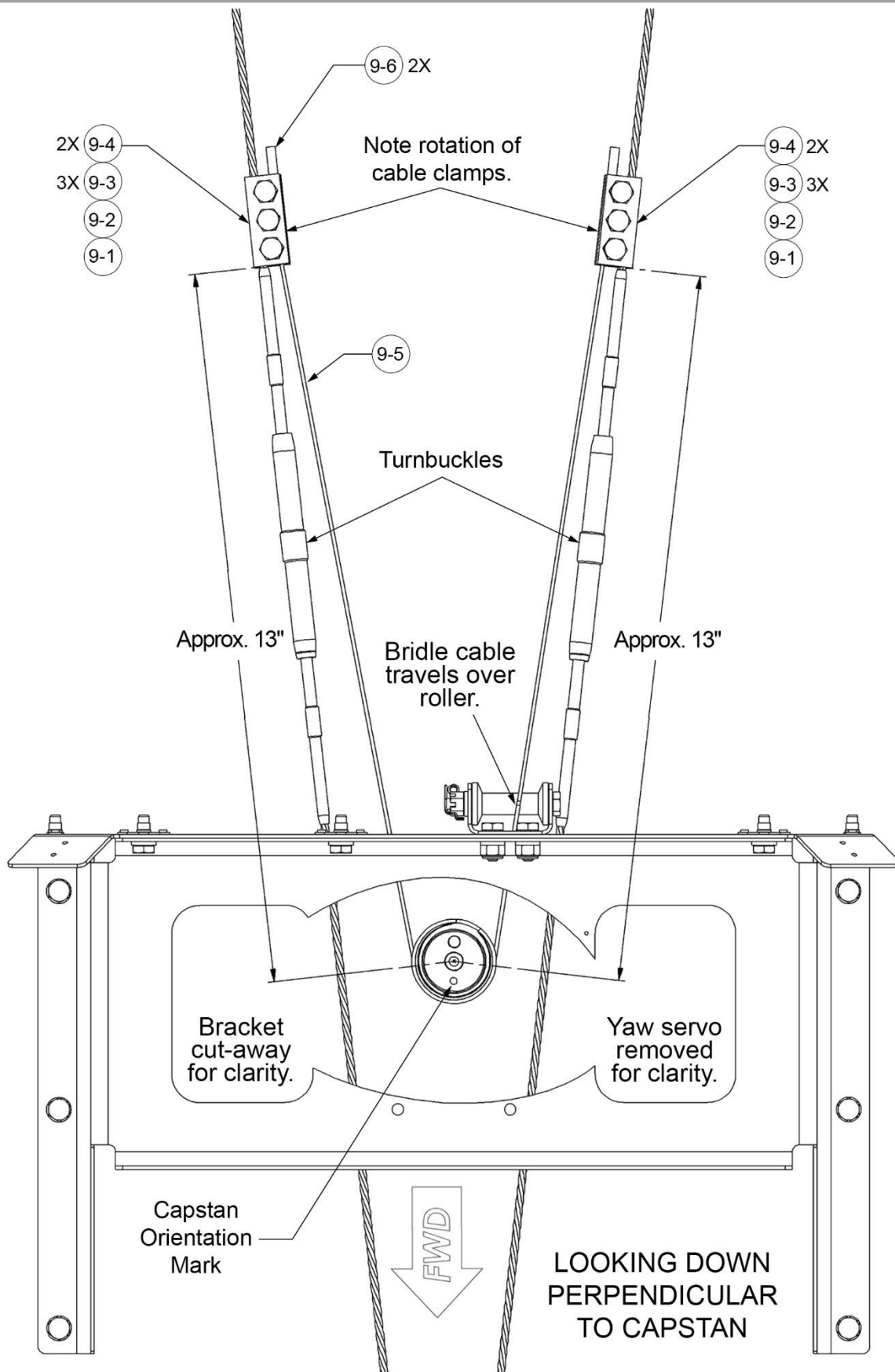

Figure 48: Connecting Yaw Servo Bridle Cable to Rudder Cable

AIRCRAFT STRUCTURE
REMOVED FOR CLARITY

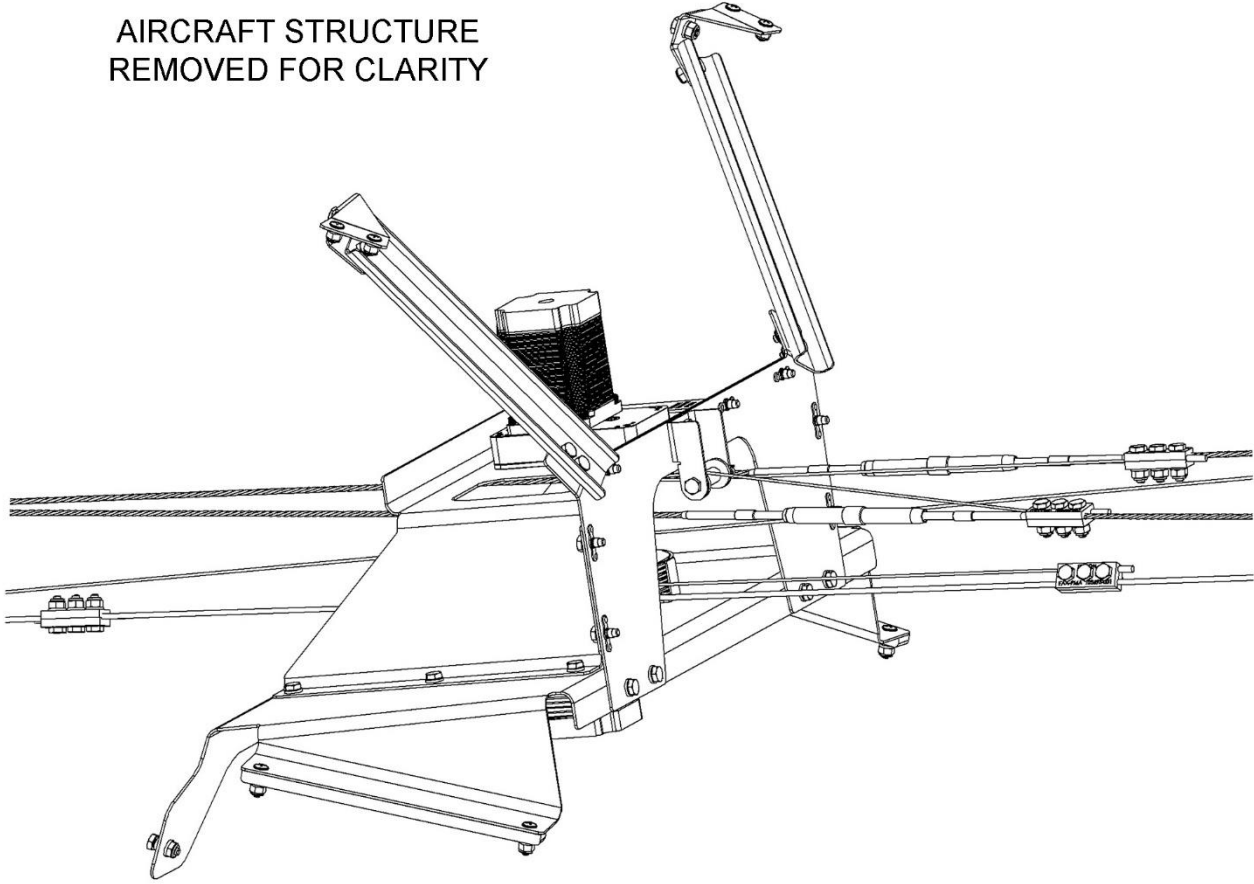

Figure 49: Pitch and Yaw Servos – Complete Installation

12.4 Servo Capstan Removal/Installation Figure

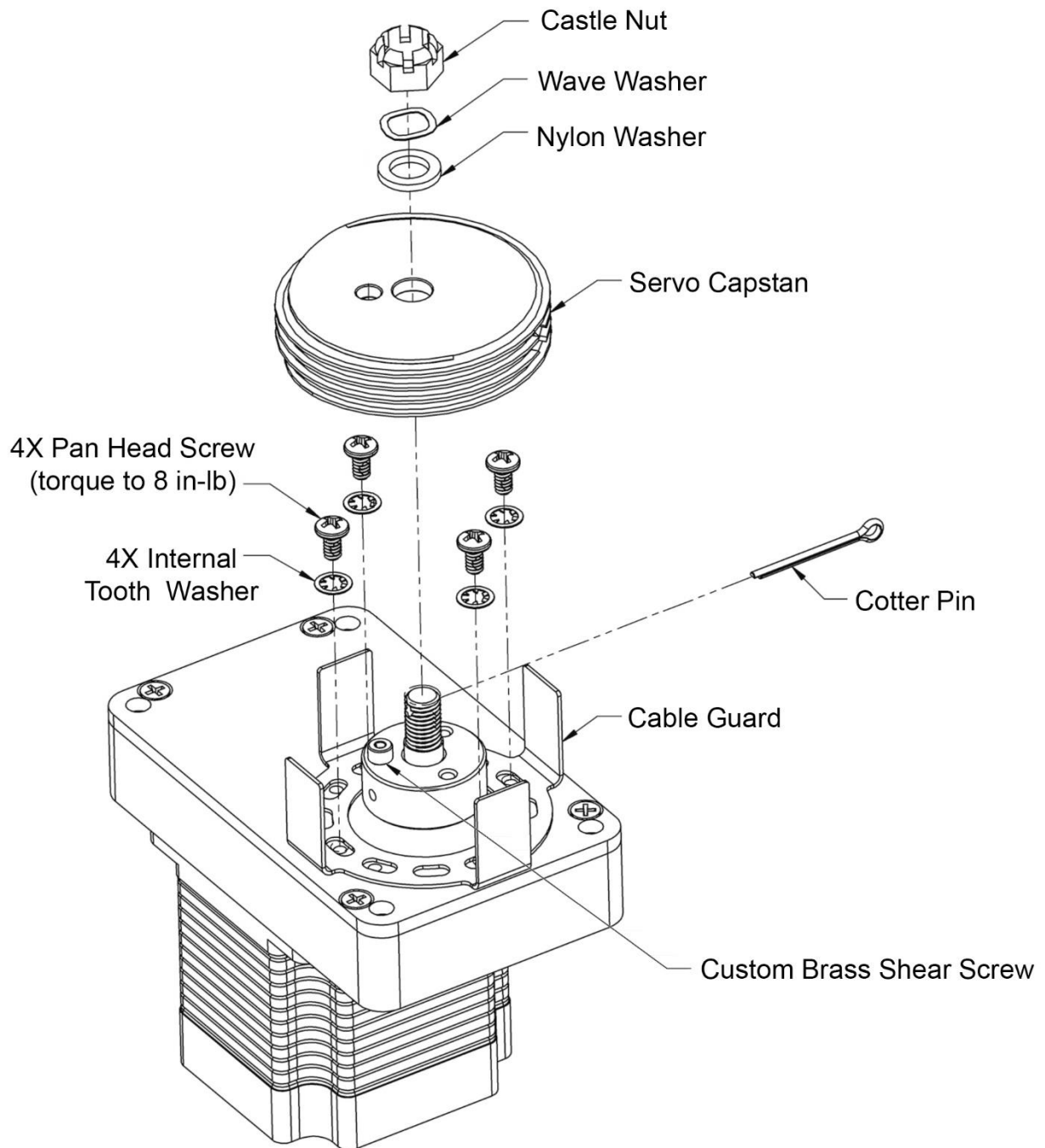

Figure 50: Exploded View of a Typical Servo Capstan Assembly