

Panel cut-out Detail
SCALE 1:2
(DO NOT SCALE DRAWING)

NOTE:
It is the responsibility of the builder to ensure the cut-out features include required margins needed for paint or other finishes applied to the panel. Finishes may reduce the effective size of the cut-out.

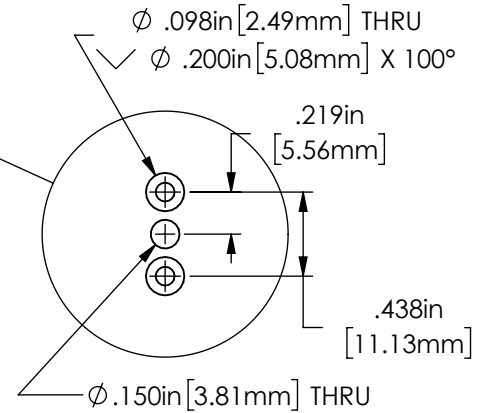

4 PLACES
HOLE DETAIL FOR MK1000-06 NUTPLATE
SCALE 1 : 1
(DO NOT SCALE DRAWING)

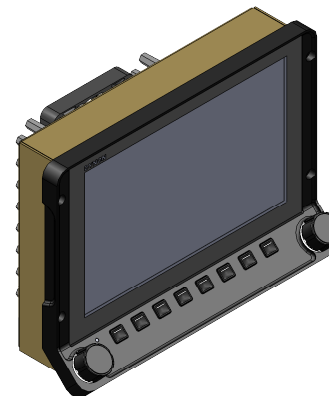
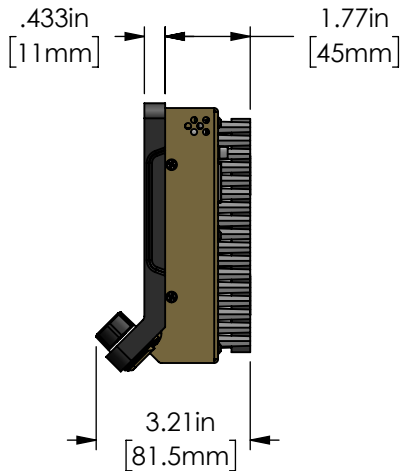
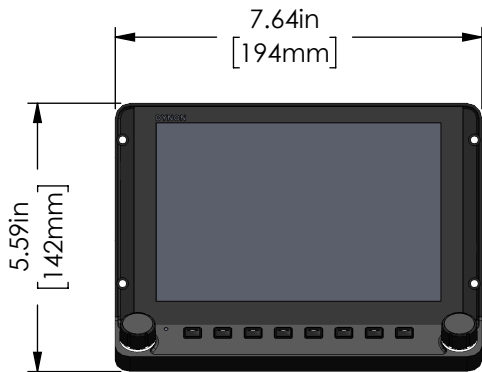

SkyView HDX
SV-HDX800
7 inch EFIS
Panel Cut-Out



19825 141st PI NE
Woodinville, WA 98072
425-402-0433
www.dynonavionics.com