



Autopilot Tiller Arm/Bow Kit for RV-10 / RV-14 Yaw Servo Installation Guide

This product is not approved for installation in type certificated aircraft

Document 102710-000, Revision A

April, 2017

Copyright © 2009-2017 by Dynon Avionics, Inc.

Permission to print this manual is granted to third parties



Contact Information

Dynon Avionics, Inc.
19825 141st Place NE
Woodinville, WA 98072
Phone: 425-402-0433 - 8:00 AM – 5:00 PM (Pacific Time) Monday – Friday
Dynon Avionics Technical Support available 7:00 AM–4:00 PM (Pacific Time) Monday – Friday
Email: support@dynonavionics.com
Fax: 425-984-1751

Dynon Avionics offers a number of Internet sites for support:

<http://www.dynonavionics.com> – Dynon Avionics primary web site; including:
<http://docs.dynonavionics.com> – Current and archival documentation.
<http://downloads.dynonavionics.com> – Software downloads.
<http://license.dynonavionics.com> – Redeem SV-MAP-270, SV-SYNVIS-280, and SV-VPX-290 licenses.
<http://store.dynonavionics.com> – Dynon Avionics' *secure* online store for purchasing all Dynon Avionics products.
<http://register.dynonavionics.com> – Register your Dynon Avionics product.
<http://support.dynonavionics.com> – Support resources.

Stay in touch with Dynon Avionics:

<http://blog.dynonavionics.com> – Dynon Avionics' blog.
<https://www.facebook.com/dynonavionics> – Dynon Avionics is on Facebook. Please “friend” us!
<http://forum.dynonavionics.com> – Dynon Avionics' Internet forum for SkyView pilots.
<http://newsletter.dynonavionics.com> – Dynon Avionics' email newsletter.
<https://twitter.com/dynon> – Dynon Avionics is on Twitter!

Training

<http://www.dynonavionics.com/videos> – Video training, including short vignettes on specific operations.
<http://www.dynonavionics.com/training> – Hands-on training at various events.

Copyright

©2009-2017 Dynon Avionics, Inc. All rights reserved. No part of this manual may be reproduced, copied, transmitted, disseminated or stored in any storage medium, for any purpose without the express written permission of Dynon Avionics. Dynon Avionics hereby grants permission to download a single copy of this manual and of any revision to this manual onto a hard drive or other electronic storage medium to be viewed for personal use, provided that such electronic or printed copy of this manual or revision must contain the complete text of this copyright notice and provided further that any unauthorized commercial distribution of this manual or any revision hereto is strictly prohibited.

Information in this document is subject to change without notice. Dynon Avionics reserves the right to change or improve its products and to make changes in the content without obligation to notify any person or organization of such changes. Visit the Dynon Avionics website (www.dynonavionics.com) for current updates and supplemental information concerning the use and operation of this and other Dynon Avionics products.

SERVO TILLER ARM INSTALLATION INSTRUCTIONS – KIT

Kit Contents		
Dynon Part #	QTY	Part Description
100904-001	1	Steel Cotter Pin 5/64IN X 3/4IN
100905-000	1	Nylon Flat Washer
101877-000	4	Cherry Rivets CCP-42
102701-000	1	Alum Tiller Arm for Yaw Damper
102702-000	1	Alum Bow for Yaw Damper

Dynon only supplies the tiller arm / bow assembly that attaches to the servo for the RV-10 and RV-14 yaw damper install. Complete installation instructions and additional aircraft installation brackets/hardware are available from Van's Aircraft.

This Tiller Arm/Bow is designed for use on RV-10 and RV-14 aircraft.

The geometry of this tiller arm may not be suitable for other aircraft.



Neglecting to properly install and/or use Dynon autopilot hardware may result in failures which could cause loss of aircraft control resulting in aircraft damage, personal injury or death.

Dynon Servo Arm/Capstan Removal

Remove the cotter pin from the castellated nut. Note that cotter pins should never be reused; **replace with a new pin**. Unthread the castellated nut, remove wave and nylon washers, and finally remove the arm or capstan. Put all these pieces aside – they will be reused. **DO NOT REMOVE the socket head safety shear screw.**

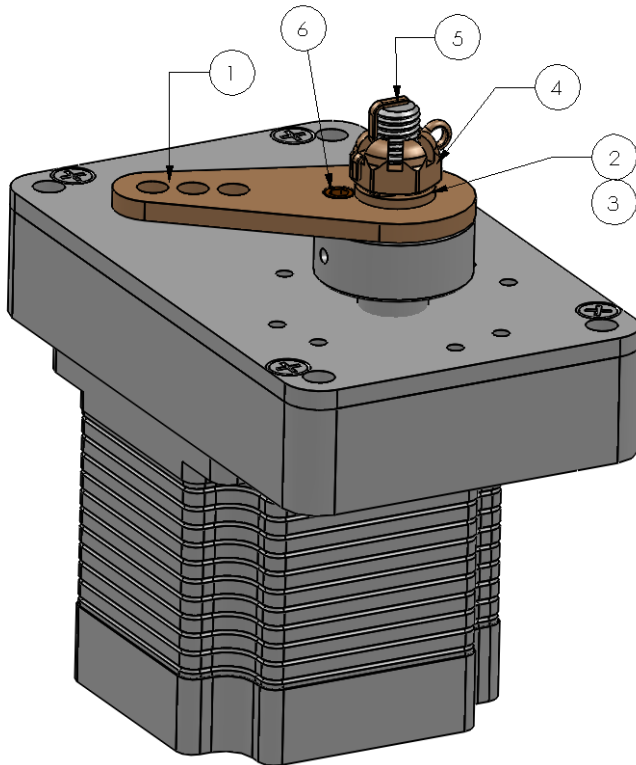

1. Servo Arm
2. Flat washer
3. Wave washer
4. Castle nut
5. Cotter pin
6. Shear screw

Required Tools

1. Needle nose Pliers
2. Torque Wrench (must be able to read 4.5 in-lb)
3. 1/2IN SAE Socket

! The autopilot safety shear screw should **NEVER** be removed or adjusted during this operation. If the shear screw has broken and needs replacement, there is specific documentation available for this purpose at <http://docs.dynonavionics.com>.

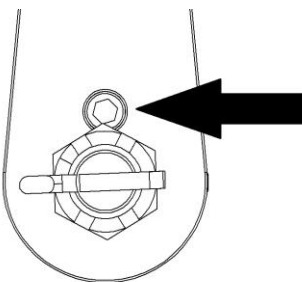

Tiller Arm Installation on Servo (Figure 2)

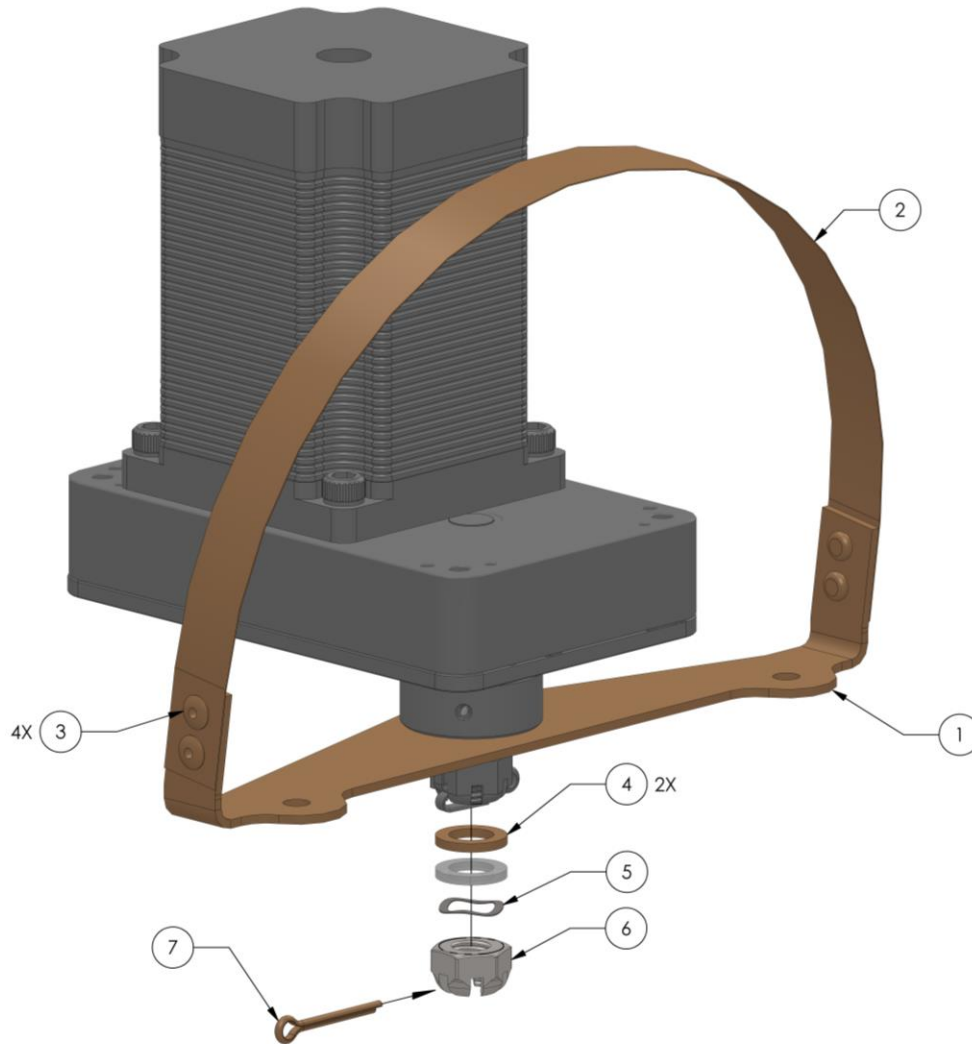

Item #	Description	Qty	Notes
1	Tiller Arm	1	Included in Yaw Damper Kit
2	Tiller Arm Bow	1	Included in Yaw Damper Kit
3	Pull Rivet	4	Included in Yaw Damper Kit
4	Nylon Flat Washer	2	Qty 1 included in Yaw Damper Kit
5	Wave Washer	1	Included with servo
6	Castle Nut	1	Included with servo
7	Cotter Pin	1	Included in Yaw Damper Kit



Reassembling the Arm Hardware Stack

Reverse the disassembly steps to install the remaining hardware. See Figure 2. Assembly order is:

1. Tiller Servo Arm
2. Nylon Washer x 2
3. Wave Washer
4. Castle Nut (AN310-5)
5. Cotter Pin (MS24665-210)

Tighten the castellated nut finger tight, and then using a Torque Wrench, tighten until a slot in the nut lines up with the hole in the shaft for the cotter pin. **DO NOT EXCEED 4.5 in-lb (72 in-oz) torque on castle nut.** Exceeding this torque specification will affect the yield torque of the safety shear screw, compromising the safety-enhancing intent of its design.

Install the new cotter pin, MS24665-210, following the standard method of trimming and bending the pin legs.

Tiller arm rotation should be smooth. No movement should be observed between the arm/capstan and the attachment disc as described earlier.

For technical support regarding this assembly please call Dynon at 425-402-0433